



# HP ProBook 4710s Notebook PC

Maintenance and Service Guide

© Copyright 2009 Hewlett-Packard  
Development Company, L.P.

AMD is a registered trademark of Advanced  
Micro Devices, Inc.

Bluetooth is a trademark owned by its  
proprietor and used by Hewlett-Packard  
Company under license. Intel, Core, and  
Celeron are trademarks of Intel Corporation  
in the United States and other countries.  
Microsoft, Windows, and Windows Vista are  
U.S. registered trademarks of Microsoft  
Corporation. SD Logo is a trademark of its  
proprietor.

The information contained herein is subject  
to change without notice. The only  
warranties for HP products and services are  
set forth in the express warranty statements  
accompanying such products and services.  
Nothing herein should be construed as  
constituting an additional warranty. HP shall  
not be liable for technical or editorial errors  
or omissions contained herein.

First Edition: April 2009

Document Part Number: 536498-001

## MSG revision history

Revision	Publication date	Description
A	October 2009	<ul style="list-style-type: none"><li>• Added information indicating support for DDR3 memory in the following location: <a href="#">Memory module on page 45</a>.</li><li>• Updated commodities in the following location: <a href="#">Product description on page 1</a>.</li><li>• Added newly supported memory modules to spare parts listings in the following locations: <a href="#">Computer major components on page 16</a>, <a href="#">Sequential part number listing on page 28</a>, <a href="#">Memory module on page 45</a>.</li><li>• Added newly supported processors to spare parts listings in the following locations: <a href="#">Computer major components on page 16</a>, <a href="#">Sequential part number listing on page 28</a>, <a href="#">Processor on page 78</a>.</li><li>• Added newly supported WLAN modules to spare parts listings in the following locations: <a href="#">Computer major components on page 16</a>, <a href="#">Sequential part number listing on page 28</a>, <a href="#">WLAN module on page 55</a>.</li><li>• Added newly supported hard drives to spare parts listings in the following locations: <a href="#">Computer major components on page 16</a>, <a href="#">Mass storage devices on page 26</a>, <a href="#">Sequential part number listing on page 28</a>, <a href="#">Hard drive on page 52</a>.</li><li>• Added a newly supported Bluetooth module to spare parts listings in the following locations: <a href="#">Computer major components on page 16</a>, <a href="#">Sequential part number listing on page 28</a>, <a href="#">Bluetooth module on page 54</a>.</li><li>• Added newly supported system boards to spare parts listings in the following locations: <a href="#">Computer major components on page 16</a>, <a href="#">Sequential part number listing on page 28</a>, <a href="#">System board on page 80</a>.</li><li>• Added newly supported AC adapter to spare parts listings in the following locations: <a href="#">Miscellaneous parts on page 27</a>, <a href="#">Sequential part number listing on page 28</a>.</li><li>• Changes to top cover descriptions in the following locations: <a href="#">Computer major components on page 16</a>, <a href="#">Sequential part number listing on page 28</a>, <a href="#">Top cover on page 65</a>.</li><li>• Deleted display cable spare part from the following locations: <a href="#">Display assembly components on page 23</a>, <a href="#">Sequential part number listing on page 28</a>, <a href="#">Display assembly on page 59</a>.</li></ul>



## Safety warning notice

- 
- ⚠ **WARNING!** To reduce the possibility of heat-related injuries or of overheating the computer, do not place the computer directly on your lap or obstruct the computer air vents. Use the computer only on a hard, flat surface. Do not allow another hard surface, such as an adjoining optional printer, or a soft surface, such as pillows or rugs or clothing, to block airflow. Also, do not allow the AC adapter to contact the skin or a soft surface, such as pillows or rugs or clothing, during operation. The computer and the AC adapter comply with the user-accessible surface temperature limits defined by the International Standard for Safety of Information Technology Equipment (IEC 60950).
-



---

# Table of contents

## 1 Product description

## 2 External component identification

Top components .....	6
Display components .....	6
TouchPad .....	7
Buttons, lights, and speakers .....	8
Keys .....	9
Front components .....	11
Right-side components .....	12
Left-side components .....	13
Bottom components .....	14

## 3 Illustrated parts catalog

Service tag .....	15
Computer major components .....	16
Display assembly components .....	23
Plastics Kit .....	24
Cable Kit .....	25
Mass storage devices .....	26
Miscellaneous parts .....	27
Sequential part number listing .....	28

## 4 Removal and replacement procedures

Preliminary replacement requirements .....	34
Tools required .....	34
Service considerations .....	34
Plastic parts .....	34
Cables and connectors .....	35
Drive handling .....	35
Grounding guidelines .....	36
Electrostatic discharge damage .....	36
Packaging and transporting guidelines .....	37

Workstation guidelines .....	37
Equipment guidelines .....	38
Component replacement procedures .....	39
Service tag .....	39
Computer feet .....	40
Battery .....	41
Switch cover and keyboard .....	42
Memory module .....	45
Optical drive .....	47
Speakers .....	49
Palm rest .....	50
Hard drive .....	52
Bluetooth module .....	54
WLAN module .....	55
Display assembly .....	59
Top cover .....	65
Power button board .....	67
Modem module .....	68
USB connector module .....	70
RTC battery .....	72
Heat sink and fan .....	74
RJ-45 (network) jack .....	76
Processor .....	78
System board .....	80

## 5 Computer Setup

Computer Setup in Windows Vista and Windows XP .....	83
Starting Computer Setup .....	83
Using Computer Setup .....	83
Navigating and selecting in Computer Setup .....	83
Restoring factory settings in Computer Setup .....	84
Computer Setup menus .....	84
File Menu .....	85
Security menu .....	85
Diagnostics menu .....	86
System Configuration menu .....	86
Computer Setup in Linux .....	89
Starting Computer Setup .....	89
Using Computer Setup .....	89
Navigating and selecting in Computer Setup .....	89
Restoring factory settings in Computer Setup .....	90
Computer Setup menus .....	90
File menu .....	90



Security menu .....	90
Diagnostics menu .....	91
System Configuration menu .....	91

## 6 Specifications

Computer specifications .....	94
17.3-inch, HD+ display specifications .....	95
Hard drive specifications .....	96
DVD±RW and CD-RW SuperMulti Double-Layer Combo Drive with LightScribe specifications .....	97
Blu-ray ROM with LightScribe DVD±RW SuperMulti DL Drive specifications .....	98
DVD-ROM Drive .....	99
System DMA specifications .....	99
System interrupt specifications .....	100
System I/O address specifications .....	101
System memory map specifications .....	103

## 7 Screw listing

Phillips PM2.0×3.0 screw .....	104
Phillips PM2.5×4.5 screw .....	108
Phillips PM3.0×4.0 screw .....	110
Phillips PM2.5×3.0 screw .....	111
Phillips PM2.0×2.0 broadhead screw .....	114
Phillips PM2.0×3.0 broadhead screw .....	115
Phillips PM2.0×4.0 screw .....	116
Phillips PM2.5×9.0 screw .....	117
Phillips PM2.5×10.0 captive screw .....	118
Phillips PM2.5×8.0 captive screw .....	120
Torx T8M2.5×6.0 screw .....	121

## 8 Backup and recovery

Backup and recovery in Windows Vista .....	123
Overview .....	123
Backing up your information .....	123
Performing a recovery .....	124
Using the Windows recovery tools .....	125
Using f11 .....	125
Using a Windows Vista operating system DVD (purchased separately) .....	126
Backup and recovery in Windows XP .....	127
Overview .....	127
Backing up your information .....	127
Performing a recovery .....	128
Recovering your information .....	128
Recovering the operating system and programs .....	128

## 9 Connector pin assignments

Audio-in (microphone) .....	129
Audio-out (headphone) .....	129
External monitor .....	130
HDMI .....	131
RJ-11 (modem) .....	132
RJ-45 (network) .....	133
Universal Serial Bus .....	133

## 10 Power cord set requirements

Requirements for all countries and regions .....	134
Requirements for specific countries and regions .....	135

## 11 Recycling

Battery .....	136
Display .....	136

<b>Index .....</b>	<b>142</b>
--------------------	------------

# 1 Product description

Category	Description
<b>Product Name</b>	HP ProBook 4710s Notebook PC
	<ul style="list-style-type: none"><li>• <i>Intel® Core™ 2 Duo T5870, 2.0 GHz, 2-MB L2 cache, 667-MHz Front Side Bus (FSB)</i></li></ul>
<b>Processors</b>	<ul style="list-style-type: none"><li>• Intel Core2 Duo T6570, 2.1 GHz, 2-MB L2 cache, TJ 100, 800-MHz FSB</li><li>• <i>Intel Core2 Duo T6670, 2.2 GHz, 2-MB L2 cache, 800-MHz FSB</i></li><li>• Intel Core2 Duo P7370, 2.0 GHz, 3-MB L2 cache, 1066-MHz FSB</li><li>• <i>Intel Core2 Duo P7570, 2.26 GHz, 3-MB L2 cache, 1066-MHz FSB</i></li><li>• Intel Core2 Duo P8600, 2.4 GHz, 3-MB L2 cache, 1066-MHz FSB</li><li>• Intel Core2 Duo P8700, 2.53 GHz, 3-MB L2 cache, 1066-MHz FSB</li><li>• Intel Core2 Duo T9400, 2.53 GHz, 6-MB L2 cache, 35W, 1066-MHz FSB</li><li>• Intel Core2 Duo T9600, 2.8 GHz, 6-MB L2 cache, 1066-MHz FSB</li><li>• <i>Intel Pentium® Dual Core T4200 2.00 GHz, 1-MB L2 cache, 800-MHz FSB</i></li><li>• <i>Intel Pentium Dual Core T4300 2.16 GHz, 1-MB L2 cache, 800-MHz FSB</i></li><li>• Intel Celeron® 585, 2.16 GHz, 2-MB L2 cache, 800-MHz FSB</li><li>• Intel Celeron 900, 2.20 GHz, 1-MB L2 cache, 800-MHz FSB</li><li>• Intel Celeron Dual-Core T1600, 1.66GHz, 1-MB L2 cache, 667-MHz FSB</li><li>• Intel Celeron Dual-Core T1700 1.83-GHz, 1-MB L2 cache, 667-MHz FSB</li><li>• <i>Intel Celeron Dual Core T3000 1.8 GHz, 1-MB L2 cache, 800-MHz FSB</i></li><li>• <i>Intel Celeron Dual Core T3100 1.9 GHz, 1-MB L2 cache, 800-MHz FSB</i></li></ul>
<b>Chipset</b>	<i>Northbridge: PM45 with up to 1066-MHz FSB</i> Southbridge: Intel ICH-9M
<b>Graphics</b>	AMD Discrete Graphics ATI-M92S2LP with Hypermemory support 512-MB DDR2-500MHz (64Mx16, Qty 4)
<b>Panels</b>	All display assemblies include 2 wireless local area network (WLAN) antennas <ul style="list-style-type: none"><li>• 17.3-inch HD+ BrightView</li><li>• 17.3-inch HD+</li><li>• 17.3-inch HD+ BrightView with camera</li></ul>

Category	Description
	<ul style="list-style-type: none"> <li>17.3-inch HD+ with camera</li> </ul>
<b>Memory</b>	2 customer-accessible/upgradable memory module slots
	Supports dual-channel memory
	Supports up to 8 GB of system RAM
	PC2-6400, 800 MHz, DDR2
	Supports the following configurations: <ul style="list-style-type: none"> <li>8192-MB total system memory (4096 × 2, dual-channel)</li> <li>4096-MB total system memory (4096 × 1)</li> </ul>
	<ul style="list-style-type: none"> <li>4096-MB total system memory (2048 × 2, dual-channel)</li> <li>3072-MB total system memory (2048 + 1024)</li> <li>2048-MB total system memory (2048 × 1)</li> <li>2048-MB total system memory (1024 × 2, dual-channel)</li> <li>1024-MB total system memory (1024 × 1)</li> </ul>
	<i>PC3-10600, 1333 MHz, DDR3</i>
	Supports the following configurations: <ul style="list-style-type: none"> <li><i>8092-MB total system memory (4096 x 2, dual-channel)</i></li> <li><i>4096-MB total system memory (4096 x 1)</i></li> <li><i>4096-MB total system memory (2048 x 2, dual-channel)</i></li> <li><i>3072-MB total system memory (2048 + 1024, dual-channel)</i></li> <li><i>2048-MB total system memory (2048 x 1)</i></li> <li><i>2048-MB total system memory (1024 x 2, dual-channel)</i></li> <li><i>1024-MB total system memory (1024 x 1)</i></li> </ul>
<b>Hard drives</b>	Supports 9.5-mm (2.5-inch) hard drives
	Customer-accessible
	Serial ATA

Category	Description
	<p>Supports the following drives:</p> <ul style="list-style-type: none"> <li>• 500-GB, 5400-rpm</li> <li>• 500-GB, 7200-rpm</li> <li>• 320-GB, 5400-rpm</li> <li>• 320-GB, 7200-rpm</li> <li>• 250-GB, 5400-rpm</li> <li>• 250-GB, 7200-rpm</li> <li>• 160-GB, 5400-rpm</li> <li>• 160-GB, 7200-rpm</li> </ul>
	HP 3D DriveGuard
<b>Optical drives</b>	Fixed (removal of 1 screw required)
	Customer-accessible
	Serial ATA
	12.7-mm tray load
	<p>Supports the following drives:</p> <ul style="list-style-type: none"> <li>• DVD±RW and CD-RW SuperMulti Double-Layer Combo Drive with LightScribe</li> <li>• Blu-ray ROM with LightScribe DVD±RW SuperMulti DL Drive</li> <li>• DVD-ROM Drive</li> </ul>
<b>Diskette drive</b>	Supports external USB diskette drive only
	Supports boot from external USB diskette drive
<b>Audio</b>	<p>HD+ audio-ADI1984AJCPZ</p> <p>Integrated microphone</p> <p>Stereo speakers (2)</p>
<b>Modem</b>	56K v.92 MDC 1.5-inch data/fax modem with digital line guard
<b>Ethernet</b>	Marvell 10/100/1000 Ethernet network interface card (NIC)
	S3/S4/S5 wake on LAN: AC=yes
<b>Wireless</b>	<b>Integrated WLAN options by way of wireless module:</b>
	2 WLAN antennas built into display assembly
	Support for no-WLAN option
	<p>Support for the following WLAN formats:</p> <ul style="list-style-type: none"> <li>• Broadcom 802.11a/b/g/n</li> <li>• Broadcom 802.11b/g</li> <li>• Intel 802.11a/b/g</li> <li>• Intel 802.11a/b/g/n</li> </ul>

Category	Description
	<ul style="list-style-type: none"> <li>Intel Wi-Fi Link 1000, 802.11b/g WLAN module</li> <li>Intel Wi-Fi Link 1000, 802.11b/g/n WLAN module</li> </ul>
	<b>Integrated personal area network (PAN) options by way of Bluetooth® module:</b>
	Support for no-WPAN option
	Bluetooth 2.0
	Bluetooth 2.1
<b>Media Card Reader</b>	One ExpressCard/34 slot
	Media Card Reader supporting Memory Stick (MS), Memory Stick Pro (MSP), MultiMediaCard (MMC), MultiMediaCard (MMC) Plus, Secure Digital (SD) Memory Card, Secure Digital High Capacity (SDHC) Memory Card, xD-Picture Card (XD), xD-Picture Card (XD) Type H, and xD-Picture Card (XD) Type M
<b>Ports</b>	Audio-in (stereo microphone)
	Audio-out (stereo headphone)
	RJ-11 (modem)
	RJ-45 (Ethernet, includes link and activity lights)
	USB (4)
	HDMI
	VGA (Dsub 15-pin) supporting 1600 × 1200 external resolution at 75-GHz (hot plug/unplug with auto-detect)
	Multi-pin AC power
<b>Keyboard/pointing devices</b>	17.3-inch keyboard with integrated numeric keypad
	TouchPad only, with 2 TouchPad buttons and vertical scrolling (taps enabled as default)
<b>Power requirements</b>	90-W Smart AC adapter with localized cable plug support (3-wire plug with ground pin)
	6-cell, 47-Wh Li-ion battery
	8-cell, 63-Wh Li-ion battery
<b>Security</b>	Supports Kensington security lock
<b>Operating system</b>	<b>Preinstalled:</b>
	<ul style="list-style-type: none"> <li>Windows 7 Professional 32</li> <li>Windows 7 Home Premium 32</li> <li>Windows Vista® Home Basic 32</li> <li>Windows Vista Home Premium 32</li> <li>Windows Vista Business 32</li> <li>Windows Vista Business 32 (with Windows® XP Pro images)</li> <li>FreeDOS</li> <li>Red Flag Linux (in the People's Republic of China only)</li> <li>SUSE Linux</li> </ul>

Category	Description
	<b>Restore media:</b>
	<ul style="list-style-type: none"> <li>• <i>Windows 7 Home Basic 32</i></li> <li>• <i>Windows 7 Home Premium 32</i></li> <li>• <i>Windows 7 Professional 32</i></li> <li>• <i>Windows 7 Professional 64</i></li> <li>• Windows Vista Home Basic 32</li> <li>• Windows Vista Home Premium 32</li> <li>• Windows Vista Business 32</li> <li>• Windows Vista Business 64</li> <li>• Windows XP Professional</li> <li>• Red Flag Linux (in the People's Republic of China only)</li> <li>• SUSE Linux</li> <li>• Windows Vista (DRDVD)</li> <li>• Windows XP Pro (DRDVD)</li> <li>• Windows Vista (Office Ready; DVD)</li> </ul>
	<b>Certified:</b> Microsoft® WHQL
	<b>Web Support:</b>
	<ul style="list-style-type: none"> <li>• Windows Vista Home Basic 32</li> <li>• Windows Vista Home Premium 32</li> <li>• Windows Vista Business 32</li> <li>• Windows Vista Business 64</li> <li>• Windows XP Professional</li> <li>• SUSE Linux</li> </ul>
<b>Serviceability</b>	<b>End-user replaceable parts:</b>
	AC adapter
	Battery (system)
	Hard drive
	Memory module
	Optical drive
	WLAN module

## 2 External component identification

### Top components

#### Display components



Item	Component	Function
(1)	Internal display switch	Turns off the display if the display is closed while the power is on.
(2)	WLAN antenna locations	Send and receive signals from one or more WLAN devices.  <b>NOTE:</b> The antennas are not visible from the outside of the computer. For optimal transmission, keep the areas immediately around the antennas free from obstructions.  To see wireless regulatory notices, refer to the section of the <i>Regulatory, Safety and Environmental Notices</i> that applies to your country or region. These notices are located in Help and Support.
(3)	Internal microphone	Records sound.



Item	Component	Function
(4)	Webcam light (select models only)	On: The integrated camera is in use.
(5)	Webcam (select models only)	Records audio and video and captures still photographs.

## TouchPad

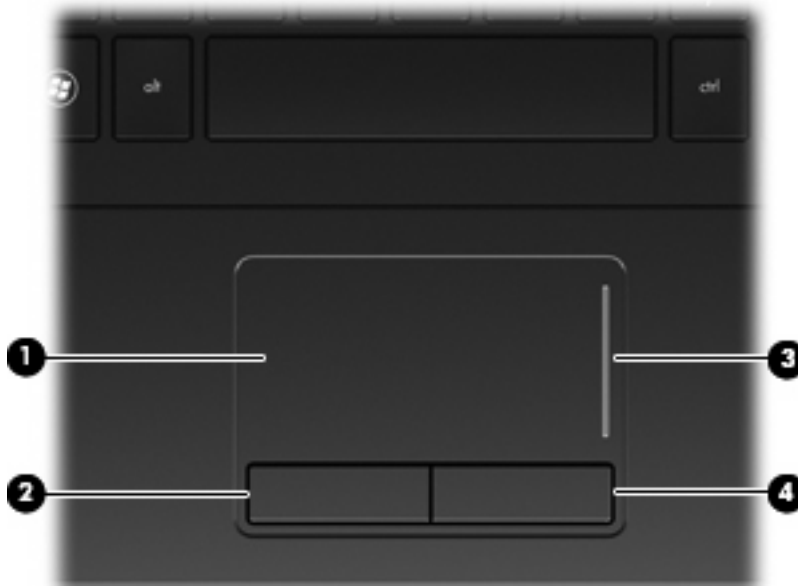

Item	Component	Function
(1)	TouchPad*	Moves the pointer and selects or activates items on the screen.
(2)	Left TouchPad button*	Functions like the left button on an external mouse.
(3)	TouchPad scroll zone	Scrolls up or down.
(4)	Right TouchPad button*	Functions like the right button on an external mouse.

\*This table describes factory settings. View or change pointing device preferences as follows:

- In Windows Vista, select **Start > Control Panel > Hardware and Sound > Mouse**.
- In Windows XP, select **Start > Control Panel > Printers and Other Hardware > Mouse**.

## Buttons, lights, and speakers

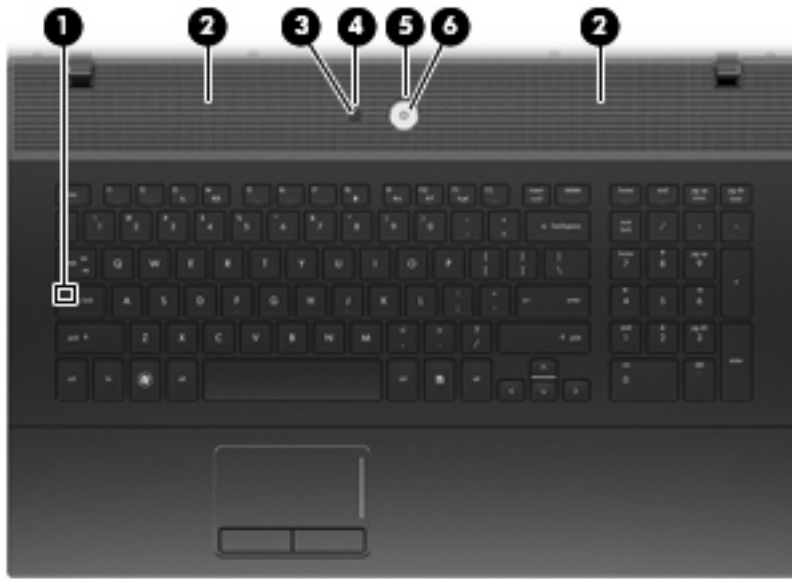

Item	Component	Function
(1)	Caps lock light	On: Caps lock is on.
(2)	Speakers (2)	Produce sound.
(3)	Info Center/QuickLook button	Launches Info Center or QuickLook.
(4)	Info Center/QuickLook light	<ul style="list-style-type: none"><li>• On: The computer is on.</li><li>• Blinking (5 times):<ul style="list-style-type: none"><li>◦ When the computer is on, press button to launch Info Center.</li><li>◦ When the computer is off or in Hibernation, press button to launch QuickLook.</li></ul></li><li>• Off: The computer is off or in the Standby or Hibernation state.</li></ul>

Item	Component	Function
(5)	Power light	<ul style="list-style-type: none"> <li>On: The computer is on.</li> <li>Blinking: The computer is in the Sleep state (Windows Vista) or Standby (Windows XP).</li> <li>Off: The computer is off or in Hibernation.</li> </ul>
(6)	Power button	<ul style="list-style-type: none"> <li>When the computer is off, press the button to turn on the computer.</li> <li>When the computer is on, press the button to shut down the computer.</li> <li>When the computer is in Standby, press the button briefly to exit Standby.</li> <li>When the computer is in Hibernation, press the button briefly to exit Hibernation.</li> </ul> <p>If the computer has stopped responding and Windows shutdown procedures are ineffective, press and hold the power button for at least 5 seconds to turn off the computer.</p>

## Keys

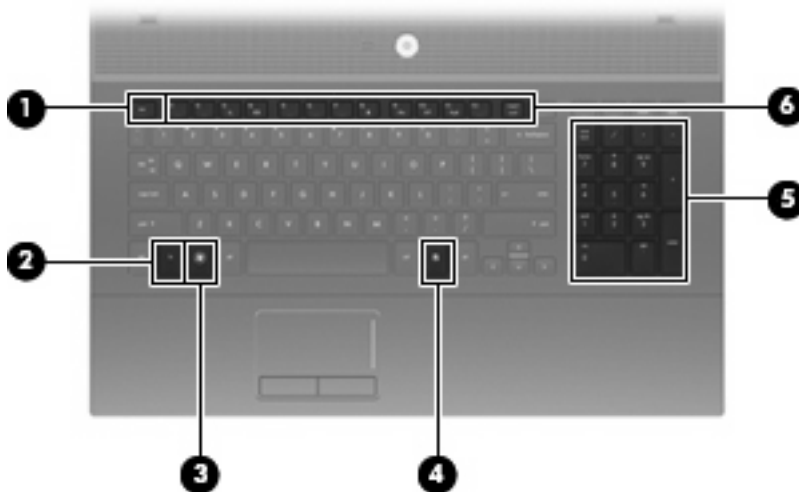

Item	Component	Function
(1)	<code>esc</code> key	Displays system information when pressed in combination with the <code>fn</code> key.
(2)	<code>fn</code> key	Executes frequently used system functions when pressed in combination with a function key or the <code>esc</code> key.
(3)	Windows logo key	Displays the Windows Start menu.
(4)	Windows applications key	Displays a shortcut menu for items beneath the pointer.

<b>Item</b>	<b>Component</b>	<b>Function</b>
(5)	Integrated numeric keypad keys	Can be used like the keys on an external numeric keypad when pressed in combination with the <b>fn</b> and <b>num lk</b> keys.
(6)	Function keys	Execute frequently used system functions when pressed in combination with the <b>fn</b> key.

## Front components



Item	Component	Function
(1)	Drive light	<ul style="list-style-type: none"> <li>Blinking turquoise. The hard drive or optical drive is being accessed.</li> <li>Amber: HP 3D DriveGuard has temporarily parked the hard drive.</li> </ul>
(2)	Wireless switch	<p>Turns the wireless feature on or off, but does not establish a wireless connection.</p> <p><b>NOTE:</b> A wireless network must be set up in order to establish a wireless connection.</p>
(3)	Wireless light	<ul style="list-style-type: none"> <li>On: An integrated wireless device, such as a wireless local area network (WLAN) device, the HP Broadband Wireless Module, and/or a Bluetooth device, is on.</li> <li>Off: All wireless devices are off.</li> </ul>
(4)	Media Card Reader	<p>Supports the following optional digital card formats:</p> <ul style="list-style-type: none"> <li>Memory Stick (MS)</li> <li>Memory Stick Pro (MSP)</li> <li>MultiMediaCard (MMC)</li> <li>MultiMediaCard (MMC) Plus</li> <li>Secure Digital (SD) Memory Card</li> <li>Secure Digital High Capacity (SDHC) Memory Card</li> <li>xD-Picture Card (XD)</li> <li>xD-Picture Card (XD) Type H</li> <li>xD-Picture Card (XD) Type M</li> </ul>
(5)	Audio-out (headphone) jack	Connects optional powered stereo speakers, headphones, ear buds, a headset, or television audio.
(6)	Audio-in (microphone) jack	Connects an optional computer headset microphone, stereo array microphone, or monaural microphone.

## Right-side components

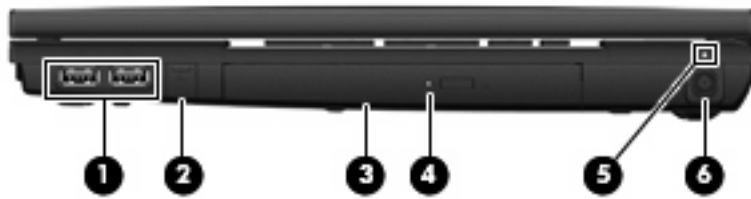

Item	Component	Function
(1)	USB ports (2)	Connect optional USB devices.
(2)	RJ-11 (modem) jack	Connects a modem cable.
(3)	Optical drive (select models only)	Reads optical discs and, on select models, also writes to optical discs.
(4)	Optical drive light (select models only)	On: The optical drive is being accessed.
(5)	Battery light	<ul style="list-style-type: none"><li>• Amber: A battery is charging.</li><li>• Turquoise: A battery is close to full charge capacity.</li><li>• Blinking amber: A battery that is the only available power source has reached a low battery level. When the battery reaches a critical battery level, the battery light begins blinking rapidly.</li><li>• Off: If the computer is plugged into an external power source, the light turns off when all batteries in the computer are fully charged. If the computer is not plugged into an external power source, the light stays off until the battery reaches a low battery level.</li></ul>
(6)	Power connector	Connects an AC adapter.

## Left-side components

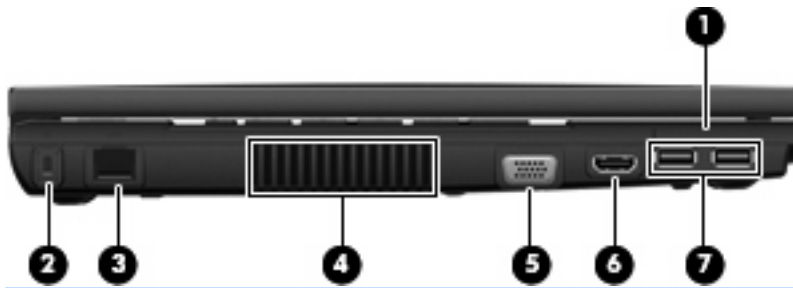

Item	Component	Function
(1)	ExpressCard slot	Supports optional ExpressCards.
(2)	Security cable slot	Attaches an optional security cable to the computer.  <b>NOTE:</b> The security cable is designed to act as a deterrent, but it may not prevent the computer from being mishandled or stolen.
(3)	RJ-45 (network) jack	Connects a network cable.
(4)	Vent	Enables airflow to cool internal components.  <b>NOTE:</b> The computer fan starts up automatically to cool internal components and prevent overheating. It is normal for the internal fan to cycle on and off during routine operation.
(5)	External monitor port	Connects an external VGA monitor or projector.
(6)	HDMI port	Connects an optional HDMI device.
(7)	USB ports (2)	Connect optional USB devices.

## Bottom components

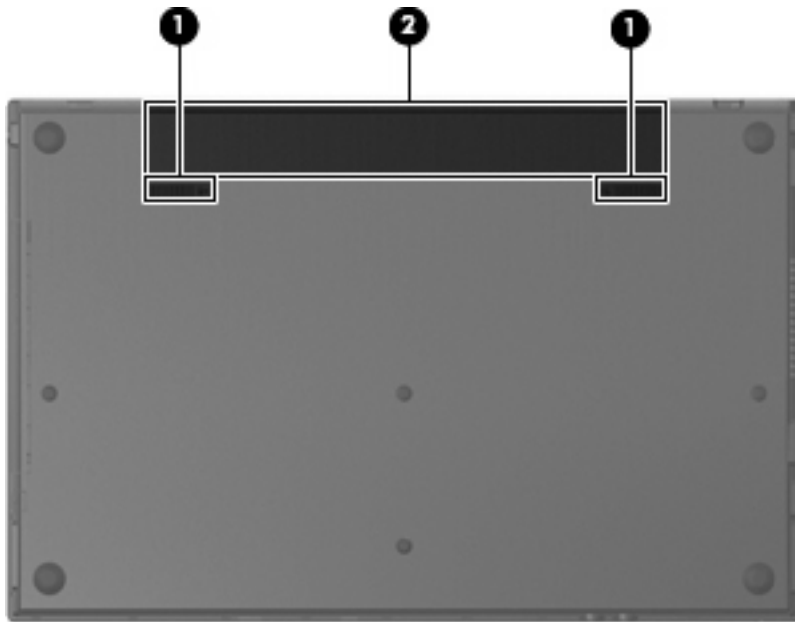

Item	Component	Function
(1)	Battery release latches (2)	Release the battery from the battery bay.
(2)	Battery bay	Holds the battery.



# 3 Illustrated parts catalog

## Service tag

The service tag, affixed to the bottom of the computer, provides information that may be needed when troubleshooting system problems. The service tag provides the following information:

- (1) Product name: This is the product name affixed to the front of the computer.
- (2) Serial number (s/n): This is an alphanumeric identifier that is unique to each product.
- (3) Part number/Product number (p/n): This number provides specific information about the product's hardware components. The part number helps a service technician to determine what components and parts are needed.
- (4) Model description: This is the alphanumeric identifier used to locate documents, drivers, and support for the computer.
- (5) Warranty period: Describes the duration of the warranty period for this computer.

When ordering parts or requesting information, provide the computer serial number and model description provided on the service tag.

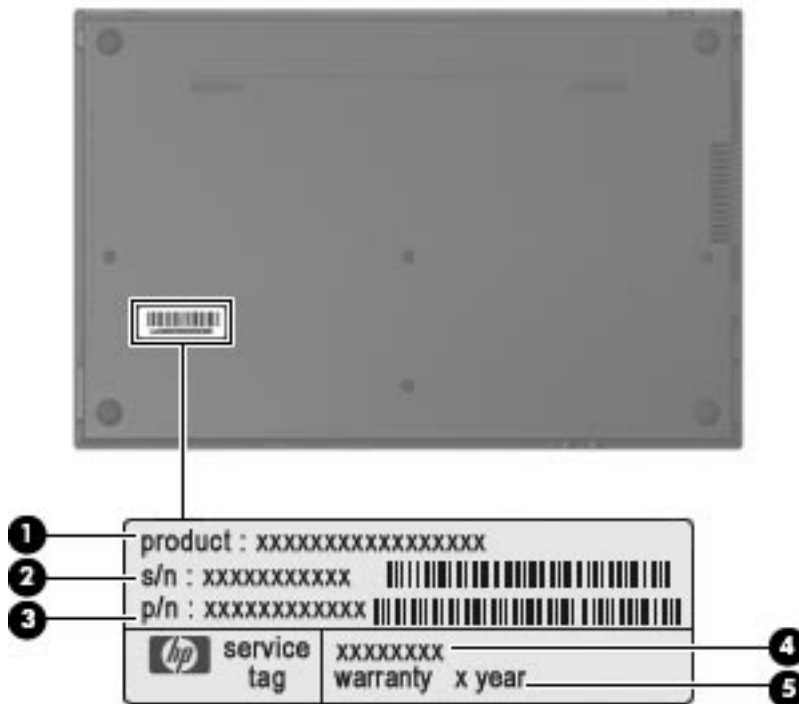

# Computer major components

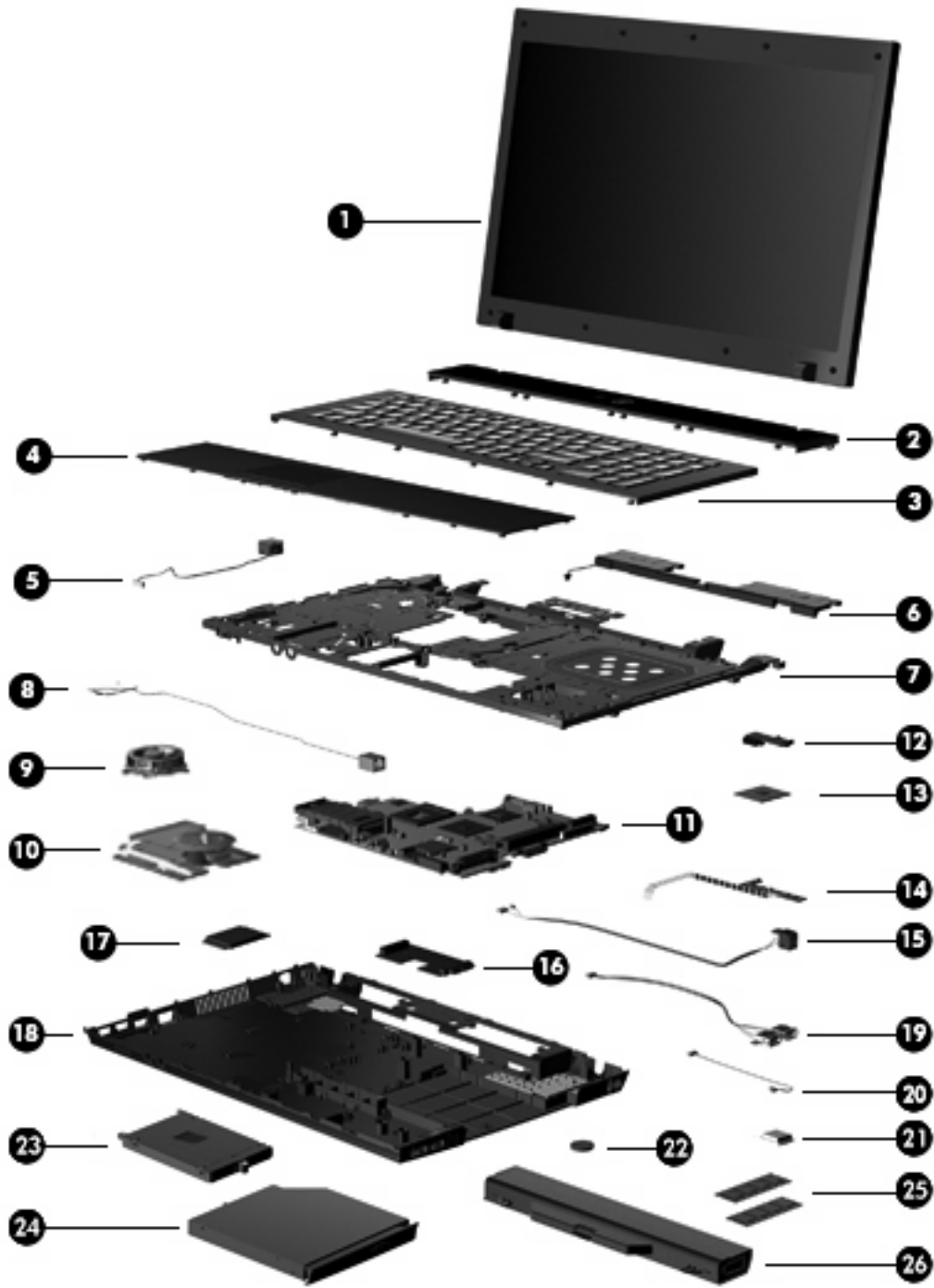

Item	Description	Spare part number
(1)	<b>Display assembly</b> (includes 2 WLAN antenna transceivers and cables)	
	17.3-inch, HD+ BrightView display assembly with camera	535777-001
	17.3-inch, HD+ BrightView display assembly	535779-001

Item	Description	Spare part number
	17.3-inch, HD+ display assembly with camera	535778-001
	17.3-inch, HD+ display assembly	535776-001
	<b>Display internal components:</b> not illustrated	
	<b>Display bezel:</b>	
	• Models equipped with a webcam	535769-001
	• Models not equipped with a webcam	535770-001
	<b>Display Cable Kit:</b> not illustrated (includes wireless antenna and webcam cables)	535771-001
	<b>Display hinges</b> (left and right hinges)	535772-001
(2)	<b>Switch cover</b>	535758-001
(3)	<b>Keyboard</b>	
	For use in Arabia	535798-171
	For use in Brazil	535798-201
	For use in Bulgaria	535798-261
	For use in Czech Republic	535798-221
	For use in Denmark	535798-081
	For use in Europe	535798-B31
	For use in Europe A4	535798-A41
	For use in French Canada	535798-121
	For use in France	535798-051
	For use in Greece	535798-DJ1
	For use in Germany	535798-041
	For use in Hungary	535798-211
	For use in Iceland	535798-DD1
	For use in Israel	535798-BB1
	For use in Italy	535798-061
	For use in Japan	535798-291
	For use in South Korea	535798-AD1
	For use in Latin America	535798-161
	For use in Norway	535798-091
	For use in Portugal	535798-131
	For use in Russia	535798-251
	For use in Sweden/Finland	535798-B71
	For use in Slovakia	535798-231
	For use in Spain	535798-071

Item	Description	Spare part number
	For use in Switzerland	535798-BG1
	For use in Thailand	535798-281
	For use in Turkey	535798-141
	For use in Taiwan	535798-AB1
	For use in United Kingdom	535798-031
	For use in the United States	535798-001
(4)	<b>Palm rest</b> (includes TouchPad)	535775-001
(5)	<b>RJ-45 (network) cable</b> (included in Cable Kit)	535757-001
(6)	<b>Speakers</b>	535795-001
(7)	<i>Top cover</i>	535796-001
(8)	<b>RJ-11 (modem) cable</b> (included in Cable Kit)	
(9)	<b>Fan</b>	535766-001
(10)	<b>Heat sink</b> (includes replacement thermal material)	535767-001
(11)	<b>System board</b> (includes replacement thermal material and the ExpressCard assembly)	
	<i>For use in computers with DDR2 memory</i>	574508-001
	<i>For use in computers with DDR3 memory</i>	583077-001
	<b>Processor</b> (includes replacement thermal material) (not illustrated)	
	<b>Intel Core2 Duo processors:</b>	
	<ul style="list-style-type: none"> <li>• <i>T5870 (2.0 GHz, 667-MHz FSB, 2-MB L2 cache)</i></li> </ul>	535835-001
	<ul style="list-style-type: none"> <li>• <i>T6570 (2.1 GHz, 800-MHz FSB, 2-MB L2 cache, TJ 100) (not available for Japan; only available with Intel WLAN or no WLAN)</i></li> </ul>	513598-001
	<ul style="list-style-type: none"> <li>• <i>T6670 (2.2 GHz, 800-MHz FSB, 2-MB L2 cache)</i></li> </ul>	572927-001
	<ul style="list-style-type: none"> <li>• <i>P7370 (2.0 GHz, 1066-MHz FSB, 3-MB L2 cache) (only available with Intel WLAN)</i></li> </ul>	507966-001
	<ul style="list-style-type: none"> <li>• <i>P7570 (2.26 GHz, 1066-MHz FSB, 3-MB L2 cache)</i></li> </ul>	572930-001
	<ul style="list-style-type: none"> <li>• <i>P8600 (2.4 GHz, 1066-MHz FSB, 3-MB L2 cache)</i></li> </ul>	507961-001
	<ul style="list-style-type: none"> <li>• <i>P8700 (2.53 GHz, 1066-MHz FSB, 3-MB L2 cache)</i></li> </ul>	507960-001
	<ul style="list-style-type: none"> <li>• <i>T9400 (2.53 GHz, 1066-MHz FSB, 6-MB L2 cache, 35W)</i></li> </ul>	507954-001
	<ul style="list-style-type: none"> <li>• <i>T9600 (2.8 GHz, 1066-MHz FSB, 6-MB L2 cache)</i></li> </ul>	507952-001
	<b>Intel Pentium Dual-Core processors:</b>	
	<ul style="list-style-type: none"> <li>• <i>T4200 (2.0 GHz, 800-MHz FSB, 1-MB L2 cache)</i></li> </ul>	513599-001
	<ul style="list-style-type: none"> <li>• <i>T4300 (2.16 GHz, 800-MHz FSB, 1-MB L2 cache)</i></li> </ul>	572929-001
	<b>Intel Celeron processors:</b>	
	<ul style="list-style-type: none"> <li>• <i>585 (2.16 GHz, 800-MHz FSB, 2-MB L2 cache)</i></li> </ul>	519898-001
	<ul style="list-style-type: none"> <li>• <i>900 (2.20 GHz, 800-MHz FSB, 1-MB L2 cache)</i></li> </ul>	534419-001

Item	Description	Spare part number
<b>Intel Celeron Dual-Core processors:</b>		
	• T1600 (1.66GHz, 667-MHz FSB, 1-MB L2 cache)	532324-001
	• T1700 (1.83-GHz, 667-MHz FSB, 1-MB L2 cache)	534084-001
	• T3000 (1.8-GHz, 800-MHz FSB, 1-MB L2 cache)	572925-001
	• T3100 (1.9-GHz, 800-MHz FSB, 1-MB L2 cache)	572926-001
(12)	<b>Battery connector board</b>	535754-001
(13)	<b>Modem module</b>	
	For use in all countries and regions except Australia and New Zealand	510100-001
	For use only in Australia and New Zealand	510100-011
(14)	<b>Power button board and cable</b>	574493-001
(15)	<b>Power connector and cable</b> (included in Cable Kit)	
(16)	<b>Battery board connector</b>	535754-001
(17)	<b>WLAN module</b>	
<b>Broadcom 802.11a/b/g/n WLAN modules:</b>		
	• Broadcom 4322 802.11a/b/g/n WLAN module for use in Antigua and Barbuda, Barbados, Belize, Canada, the Cayman Islands, Guam, Puerto Rico, Trinidad and Tobago, the U.S. Virgin Islands, and the United States	504664-001
	• Broadcom 4322 802.11a/b/g/n WLAN module for use in Afghanistan, Albania, Algeria, Andorra, Angola, Antigua and Barbuda, Argentina, Armenia, Aruba, Australia, Austria, Azerbaijan, the Bahamas, Bahrain, Bangladesh, Barbados, Belarus, Belgium, Belize, Benin, Bermuda, Bhutan, Bolivia, Bosnia and Herzegovina, Botswana, Brazil, the British Virgin Islands, Brunei, Bulgaria, Burkina Faso, Burundi, Cameroon, Cape Verde, the Central African Republic, Chad, Chile, the People's Republic of China, Colombia, Comoros, the Congo, Costa Rica, Croatia, Cyprus, the Czech Republic, Denmark, Djibouti, Dominica, the Dominican Republic, East Timor, Ecuador, Egypt, El Salvador, Equatorial Guinea, Eritrea, Estonia, Ethiopia, Fiji, Finland, France, French Guiana, Gabon, Gambia, Georgia, Germany, Ghana, Gibraltar, Greece, Grenada, Guadeloupe, Guatemala, Guinea, Guinea-Bissau, Guyana, Haiti, Honduras, Hong Kong, Hungary, Iceland, India, Ireland, Israel, Italy, the Ivory Coast, Jamaica, Jordan, Kazakhstan, Kenya, Kiribati, Kyrgyzstan, Laos, Latvia, Lebanon, Lesotho, Liberia, Liechtenstein, Lithuania, Luxembourg, Macedonia, Madagascar, Malawi, Malaysia, the Maldives, Mali, Malta, the Marshall Islands, Martinique, Mauritania, Mauritius, Mexico, Micronesia, Monaco, Mongolia, Montenegro, Morocco, Mozambique, Namibia, Nauru, Nepal, the Nether Antilles, the Netherlands, New Zealand, Nicaragua, Niger, Nigeria, Norway, Oman, Pakistan, Palau, Panama, Papua New Guinea, Paraguay, Peru, the Philippines, Poland, Portugal, the Republic of Moldova, Romania, Russia, Rwanda, Samoa, San Marino, Sao Tome and Principe, Saudi Arabia, Senegal, Serbia, the Seychelles, Sierra Leone, Singapore, Slovakia, Slovenia, the Solomon Islands, Somalia, South Africa, South Korea, Spain, Sri Lanka, St. Kitts and Nevis, St. Lucia, St. Vincent and the Grenadines, Suriname, Swaziland, Sweden, Switzerland, Taiwan, Tajikistan, Tanzania, Togo, Tonga, Trinidad and Tobago, Tunisia, Turkey, Turkmenistan, Tuvalu, Uganda, Ukraine, the United Arab Emirates, the United Kingdom, Uruguay, Uzbekistan, Vanuatu, Venezuela, Vietnam, Yemen, Zaire, Zambia, and Zimbabwe	504664-002
<b>Broadcom 802.11b/g WLAN modules:</b>		
	• Broadcom 4312 802.11b/g WLAN module: For use in Antigua and Barbuda, Barbados, Belize, Canada, the Cayman Islands, Guam, Puerto Rico, Trinidad and Tobago, the U.S. Virgin Islands, and the United States	504593-003

Item	Description	Spare part number
•	For use in Afghanistan, Albania, Algeria, Andorra, Angola, Antigua and Barbuda, Argentina, Armenia, Aruba, Australia, Austria, Azerbaijan, the Bahamas, Bahrain, Bangladesh, Barbados, Belarus, Belgium, Belize, Benin, Bermuda, Bhutan, Bolivia, Bosnia and Herzegovina, Botswana, Brazil, the British Virgin Islands, Brunei, Bulgaria, Burkina Faso, Burundi, Cameroon, Cape Verde, the Central African Republic, Chad, Chile, the People's Republic of China, Colombia, Comoros, the Congo, Costa Rica, Croatia, Cyprus, the Czech Republic, Denmark, Djibouti, Dominica, the Dominican Republic, East Timor, Ecuador, Egypt, El Salvador, Equatorial Guinea, Eritrea, Estonia, Ethiopia, Fiji, Finland, France, French Guiana, Gabon, Gambia, Georgia, Germany, Ghana, Gibraltar, Greece, Grenada, Guadeloupe, Guatemala, Guinea, Guinea-Bissau, Guyana, Haiti, Honduras, Hong Kong, Hungary, Iceland, India, Ireland, Israel, Italy, the Ivory Coast, Jamaica, Jordan, Kazakhstan, Kenya, Kiribati, Kyrgyzstan, Laos, Latvia, Lebanon, Lesotho, Liberia, Liechtenstein, Lithuania, Luxembourg, Macedonia, Madagascar, Malawi, Malaysia, the Maldives, Mali, Malta, the Marshall Islands, Martinique, Mauritania, Mauritius, Mexico, Micronesia, Monaco, Mongolia, Montenegro, Morocco, Mozambique, Namibia, Nauru, Nepal, the Nether Antilles, the Netherlands, New Zealand, Nicaragua, Niger, Nigeria, Norway, Oman, Pakistan, Palau, Panama, Papua New Guinea, Paraguay, Peru, the Philippines, Poland, Portugal, the Republic of Moldova, Romania, Russia, Rwanda, Samoa, San Marino, Sao Tome and Principe, Saudi Arabia, Senegal, Serbia, the Seychelles, Sierra Leone, Singapore, Slovakia, Slovenia, the Solomon Islands, Somalia, South Africa, South Korea, Spain, Sri Lanka, St. Kitts and Nevis, St. Lucia, St. Vincent and the Grenadines, Suriname, Swaziland, Sweden, Switzerland, Taiwan, Tajikistan, Tanzania, Togo, Tonga, Trinidad and Tobago, Tunisia, Turkey, Turkmenistan, Tuvalu, Uganda, Ukraine, the United Arab Emirates, the United Kingdom, Uruguay, Uzbekistan, Vanuatu, Venezuela, Vietnam, Yemen, Zaire, Zambia, and Zimbabwe	504593-004
	<b>Intel Wi-Fi Link 5100 802.11a/b/g WLAN module</b> for use in all countries and regions	482957-001
	<b>Intel Wi-Fi Link 5100 802.11a/b/g/n WLAN module</b> for use in all countries and regions	480985-001
	<i>Broadcom 4322 AGN 802.11a/b/g WLAN modules:</i>	
•	<i>For use in Antigua and Barbuda, Barbados, Belize, Canada, the Cayman Islands, Guam, Puerto Rico, Trinidad and Tobago, the U.S. Virgin Islands, and the United States</i>	518434-001
•	<i>For use in Afghanistan, Albania, Algeria, Andorra, Angola, Antigua and Barbuda, Argentina, Armenia, Aruba, Australia, Austria, Azerbaijan, the Bahamas, Bahrain, Bangladesh, Barbados, Belarus, Belgium, Belize, Benin, Bermuda, Bhutan, Bolivia, Bosnia and Herzegovina, Botswana, Brazil, the British Virgin Islands, Brunei, Bulgaria, Burkina Faso, Burundi, Cameroon, Cape Verde, the Central African Republic, Chad, Chile, the People's Republic of China, Colombia, Comoros, the Congo, Costa Rica, Croatia, Cyprus, the Czech Republic, Denmark, Djibouti, Dominica, the Dominican Republic, East Timor, Ecuador, Egypt, El Salvador, Equatorial Guinea, Eritrea, Estonia, Ethiopia, Fiji, Finland, France, French Guiana, Gabon, Gambia, Georgia, Germany, Ghana, Gibraltar, Greece, Grenada, Guadeloupe, Guatemala, Guinea, Guinea-Bissau, Guyana, Haiti, Honduras, Hong Kong, Hungary, Iceland, India, Ireland, Israel, Italy, the Ivory Coast, Jamaica, Jordan, Kazakhstan, Kenya, Kiribati, Kyrgyzstan, Laos, Latvia, Lebanon, Lesotho, Liberia, Liechtenstein, Lithuania, Luxembourg, Macedonia, Madagascar, Malawi, Malaysia, the Maldives, Mali, Malta, the Marshall Islands, Martinique, Mauritania, Mauritius, Mexico, Micronesia, Monaco, Mongolia, Montenegro, Morocco, Mozambique, Namibia, Nauru, Nepal, the Nether Antilles, the Netherlands, New Zealand, Nicaragua, Niger, Nigeria, Norway, Oman, Pakistan, Palau, Panama, Papua New Guinea, Paraguay, Peru, the Philippines, Poland, Portugal, the Republic of Moldova, Romania, Russia, Rwanda, Samoa, San Marino, Sao Tome and Principe, Saudi Arabia, Senegal, Serbia, the Seychelles, Sierra Leone, Singapore, Slovakia, Slovenia, the Solomon Islands, Somalia, South Africa, South Korea, Spain, Sri Lanka, St. Kitts and Nevis, St. Lucia, St. Vincent and the Grenadines, Suriname, Swaziland, Sweden, Switzerland, Taiwan, Tajikistan, Tanzania, Togo, Tonga, Trinidad and Tobago, Tunisia, Turkey, Turkmenistan, Tuvalu, Uganda, Ukraine, the United Arab Emirates, the United Kingdom, Uruguay, Uzbekistan, Vanuatu, Venezuela, Vietnam, Yemen, Zaire, Zambia, and Zimbabwe</i>	518434-002

Item	Description	Spare part number
	<i>Intel Wi-Fi Link 1000, 802.11b/g/n WLAN module:</i>	
	<ul style="list-style-type: none"> <li>For use in Andorra, Antigua and Barbuda, Argentina, Aruba, Australia, Austria, Azerbaijan, the Bahamas, Barbados, Belgium, Bolivia, Bosnia and Herzegovina, Brazil, Brunei, Bulgaria, Canada, Cayman Islands, Chile, China, Colombia, Costa Rica, Croatia, Cyprus, the Czech Republic, Denmark, the Dominican Republic, Ecuador, Egypt, El Salvador, Estonia, Finland, France, French Guiana, Guadeloupe, Guam, Georgia, Germany, Ghana, Greece, Guatemala, Haiti, Honduras, Hong Kong, Hungary, Iceland, India, Indonesia, Ireland, Israel, Italy, Ivory Coast, Jamaica, Japan, Jordan, Kenya, Kuwait, Kyrgyzstan, Latvia, Lebanon, Liechtenstein, Lithuania, Luxembourg, Malawi, Malaysia, Malta, Martinique, Mauritius, Mexico, Monaco, Montenegro, Morocco, the Nether Antilles, the Netherlands, New Zealand, Nicaragua, Nigeria, Oman, Pakistan, Panama, Paraguay, Peru, the Philippines, Poland, Portugal, Puerto Rico, Qatar, Romania, San Marino, Saudi Arabia, Senegal, Singapore, Slovakia, Slovenia, South Africa, South Korea, Spain, Sri Lanka, Sweden, Switzerland, Taiwan, Tanzania, Thailand, Trinidad and Tobago, Turkey, United Arab Emirates, the United Kingdom, the United States, Uruguay, the U.S. Virgin Islands, Venezuela, and Vietnam</li> </ul>	572520-001
	<i>Intel Wi-Fi Link 1000, 802.11b/g WLAN module:</i>	
	<ul style="list-style-type: none"> <li>For use in Russia and Ukraine</li> </ul>	585984-001
(18)	<b>Base enclosure</b> (includes rubber feet)	535752-001
	<b>Rubber Kit</b> (not illustrated, contains 7 computer feet and 8 display bezel screw covers)	535793-001
(19)	<b>USB connector and cable</b> (not illustrated; see <a href="#">Cable Kit on page 25</a> for more Cable Kit spare part number information)	535757-001
(20)	<b>Bluetooth cable</b> (included in Cable Kit)	
(21)	<b>Bluetooth module</b>	
	<i>Bluetooth 2.0 module</i>	398393-002
	<i>Bluetooth 2.1 module</i>	537921-001
(22)	<b>RTC battery</b>	449137-001
(23)	<b>Hard drive</b> (includes hard drive bracket)	
	500-GB, 5400-rpm	535765-001
	500-GB, 7200-rpm	574720-001
	320-GB, 5400-rpm	535764-001
	320-GB, 7200-rpm	574719-001
	250-GB, 5400-rpm	535763-001
	250-GB, 7200-rpm	572817-001
	160-GB, 5400-rpm	535762-001
	160-GB, 7200-rpm	572816-001
(24)	<b>Optical drive</b> (includes bezel and bracket)	
	DVD±RW and CD-RW SuperMulti Double-Layer Combo Drive with LightScribe	535761-001
	Blu-ray ROM with LightScribe DVD±RW SuperMulti DL Drive	535759-001
	DVD-ROM Drive	535760-001
(25)	<b>Memory modules</b> (PC2-6400, 800-MHz, DDR2)	

<b>Item</b>	<b>Description</b>	<b>Spare part number</b>
	<i>For use in models that use DDR2 memory</i>	
	<ul style="list-style-type: none"> <li>• 1-GB (PC2-6400, 800-MHz, DDR2)</li> </ul>	535773-001
	<ul style="list-style-type: none"> <li>• 2-GB (PC2-6400, 800-MHz, DDR2)</li> </ul>	535774-001
	<i>For use in models that use DDR3 memory</i>	
	<ul style="list-style-type: none"> <li>• 2-GB (PC3-10600, 1333-MHz, DDR3)</li> </ul>	583074-001
	<ul style="list-style-type: none"> <li>• 1-GB (PC3-10600, 1333-MHz, DDR3)</li> </ul>	583073-001
<b>(26)</b>	<b>8-cell, 63-Wh Li-ion battery</b>	535753-001



## Display assembly components

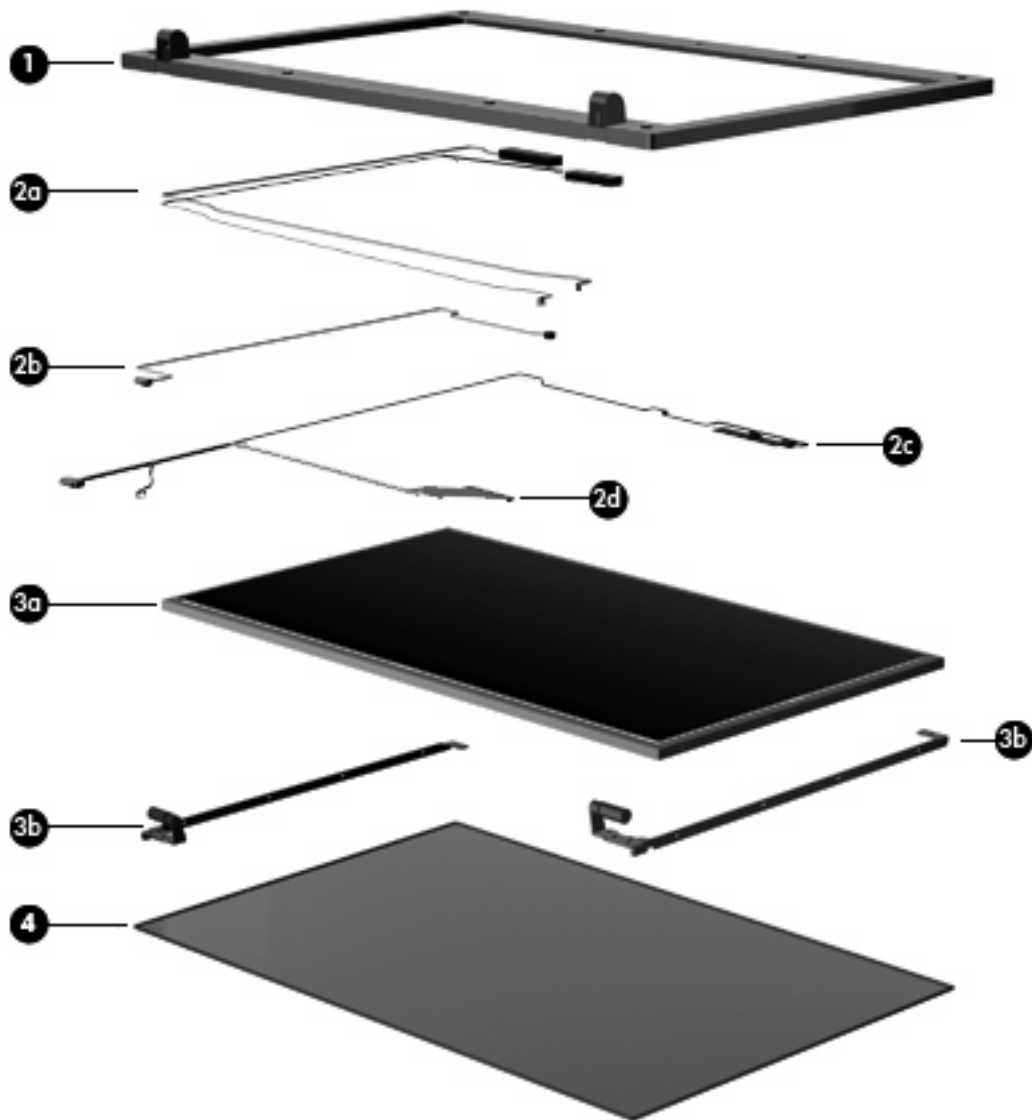

Item	Description	Spare part number
<b>(1)</b>	<b>Display Bezel</b>	
	Display bezel with webcam	535769-001
	Display bezel without a webcam	535770-001
	<b>Display Cable Kit, includes:</b>	535771-001
<b>(2a)</b>	Webcam module cable	
<b>(2b)</b>	Microphone cable	
<b>(2c)</b>	Wireless antenna transceivers and cables	
<b>(2d)</b>	Display panel cable	
	<b>Display Hinge Kit, includes:</b>	535772-001

(3a)	Display hinge bracket	
(3b)	Display left and right hinges	
(4)	<b>Display enclosure</b>	535768-001

## Plastics Kit



Item	Description	Spare part number
	<b>Plastics Kit:</b>	535780-001
(1)	ExpressCard slot bezel	
(2)	Optical drive bezel	

## Cable Kit

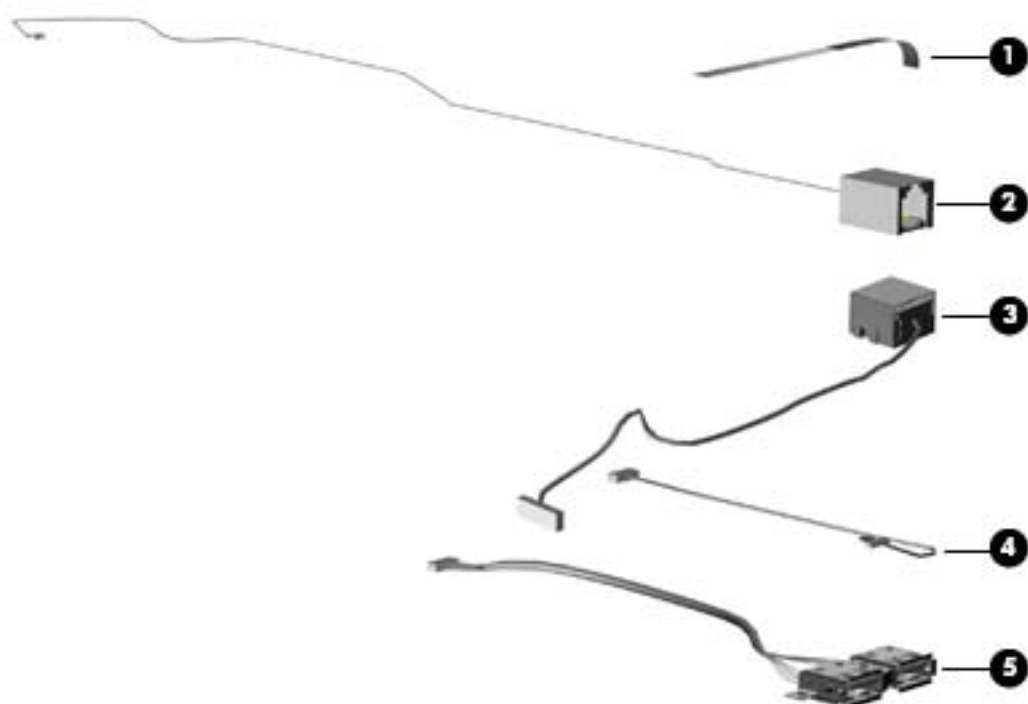

Item	Description	Spare part number
	<b>Cable Kit</b>	535757-001
(1)	TouchPad cable	
(2)	RJ-11 (modem) jack cable	
(3)	RJ-45 (network) jack cable	
(4)	Bluetooth cable	
(5)	USB cable	

## Mass storage devices



Item	Description	Spare part number
<b>(1)</b>	<b>Optical drives</b> (include bezel and bracket)	
	DVD±RW and CD-RW SuperMulti Double-Layer Combo Drive with LightScribe	535761-001
	Blu-ray ROM with LightScribe DVD±RW SuperMulti DL Drive	535759-001
	DVD-ROM Drive	535760-001
<b>(2)</b>	<b>Hard drives</b> (include bracket)	
	500-GB, 5400-rpm	535765-001
	500-GB, 7200-rpm	574720-001
	320-GB, 5400-rpm	535764-001
	320-GB, 7200-rpm	574719-001
	250-GB, 5400-rpm	535763-001
	250-GB, 7200-rpm	572817-001
	160-GB, 5400-rpm	535762-001
	160-GB, 7200-rpm	572816-001

## Miscellaneous parts

Description	Spare part number
<b>90-W Smart AC adapter</b>	463955-001
<i>90-W Smart AC adapter for use in South Korea</i>	463956-001
<i>90-W Smart AC adapter for use in India</i>	535593-001
<b>Logo Kit</b>	571385-001
<b>Display rubber kit</b>	571378-001
<b>Display screw kit</b>	571381-001
<b>Power cords:</b>	
For use in the United States	246959-001
For use in Australia and New Zealand	246959-011
For use in Europe, the Middle East, and Africa	246959-021
For use in the United Kingdom	246959-031
For use in Italy	246959-061
For use in Denmark	246959-081
For use in Brazil	246959-201
For use in Japan	246959-291
For use in South Korea	246959-AD1
For use in Israel	246959-BB1
<b>Screw Kit</b>	535794-001
Screw kits include:	
<ul style="list-style-type: none"> <li>• Phillips PM2.0×3.0 screw</li> <li>• Phillips PM2.0×4.0 screw</li> <li>• Phillips PM2.5×3.0 screw</li> <li>• Phillips PM2.5×4.5 screw</li> <li>• Phillips PM2.5×5.0 screw</li> <li>• Phillips PM2.5×9.0 screw</li> <li>• Phillips PM2.5×10.0 captive screw</li> <li>• Phillips PM2.0×2.0 broadhead screw</li> <li>• Phillips PM2.0×3.0 broadhead screw</li> <li>• Phillips PM3.0×4.0 screw</li> <li>• Torx T8M2.5×6.0 screw</li> </ul>	

## Sequential part number listing

Spare part number	Description
246959-001	Power cord for use in the United States
246959-011	Power cord for use in Australia
246959-021	Power cord for use in Europe
246959-031	Power cord for use in the United Kingdom
246959-061	Power cord for use in Italy
246959-081	Power cord for use in Denmark
246959-201	Power cord for use in Brazil
246959-291	Power cord for use in Japan
246959-AD1	Power cord for use in South Korea
246959-AG1	Power cord for use in Switzerland
246959-BB1	Power cord for use in Israel
398393-002	Bluetooth 2.0 module for use in all countries and regions except Japan and Asia Pacific
449137-001	RTC battery
463955-001	90-W Smart AC adapter for use in all countries and regions except India
463956-001	<i>90-W Smart AC adapter for use in South Korea</i>
480985-001	Intel Wi-Fi Link 5100 802.11a/b/g/n WLAN module for use in all countries and regions
482957-001	<i>Intel Wi-Fi Link 5100 802.11a/b/g WLAN module for use in all countries and regions</i>
504593-003	Broadcom 4312 802.11b/g WLAN module: For use in Antigua and Barbuda, Barbados, Belize, Canada, the Cayman Islands, Guam, Puerto Rico, Trinidad and Tobago, the U.S. Virgin Islands, and the United States
504593-004	For use in Afghanistan, Albania, Algeria, Andorra, Angola, Antigua and Barbuda, Argentina, Armenia, Aruba, Australia, Austria, Azerbaijan, the Bahamas, Bahrain, Bangladesh, Barbados, Belarus, Belgium, Belize, Benin, Bermuda, Bhutan, Bolivia, Bosnia and Herzegovina, Botswana, Brazil, the British Virgin Islands, Brunei, Bulgaria, Burkina Faso, Burundi, Cameroon, Cape Verde, the Central African Republic, Chad, Chile, the People's Republic of China, Colombia, Comoros, the Congo, Costa Rica, Croatia, Cyprus, the Czech Republic, Denmark, Djibouti, Dominica, the Dominican Republic, East Timor, Ecuador, Egypt, El Salvador, Equatorial Guinea, Eritrea, Estonia, Ethiopia, Fiji, Finland, France, French Guiana, Gabon, Gambia, Georgia, Germany, Ghana, Gibraltar, Greece, Grenada, Guadeloupe, Guatemala, Guinea, Guinea-Bissau, Guyana, Haiti, Honduras, Hong Kong, Hungary, Iceland, India, Ireland, Israel, Italy, the Ivory Coast, Jamaica, Jordan, Kazakhstan, Kenya, Kiribati, Kyrgyzstan, Laos, Latvia, Lebanon, Lesotho, Liberia, Liechtenstein, Lithuania, Luxembourg, Macedonia, Madagascar, Malawi, Malaysia, the Maldives, Mali, Malta, the Marshall Islands, Martinique, Mauritania, Mauritius, Mexico, Micronesia, Monaco, Mongolia, Montenegro, Morocco, Mozambique, Namibia, Nauru, Nepal, the Nether Antilles, the Netherlands, New Zealand, Nicaragua, Niger, Nigeria, Norway, Oman, Pakistan, Palau, Panama, Papua New Guinea, Paraguay, Peru, the Philippines, Poland, Portugal, the Republic of Moldova, Romania, Russia, Rwanda, Samoa, San Marino, Sao Tome and Principe, Saudi Arabia, Senegal, Serbia, the Seychelles, Sierra Leone, Singapore, Slovakia, Slovenia, the Solomon Islands, Somalia, South Africa, South Korea, Spain, Sri Lanka, St. Kitts and Nevis, St. Lucia, St. Vincent and the Grenadines, Suriname, Swaziland, Sweden, Switzerland, Taiwan, Tajikistan, Tanzania, Togo, Tonga, Trinidad and Tobago, Tunisia, Turkey, Turkmenistan, Tuvalu, Uganda, Ukraine, the United Arab Emirates, the United Kingdom, Uruguay, Uzbekistan, Vanuatu, Venezuela, Vietnam, Yemen, Zaire, Zambia, and Zimbabwe
504664-001	Broadcom 4322 802.11a/b/g/n WLAN module for use in Antigua and Barbuda, Barbados, Belize, Canada, the Cayman Islands, Guam, Puerto Rico, Trinidad and Tobago, the U.S. Virgin Islands, and the United States

<b>Spare part number</b>	<b>Description</b>
504664-002	Broadcom 4322 802.11a/b/g/n WLAN module for use in Afghanistan, Albania, Algeria, Andorra, Angola, Antigua and Barbuda, Argentina, Armenia, Aruba, Australia, Austria, Azerbaijan, the Bahamas, Bahrain, Bangladesh, Barbados, Belarus, Belgium, Belize, Benin, Bermuda, Bhutan, Bolivia, Bosnia and Herzegovina, Botswana, Brazil, the British Virgin Islands, Brunei, Bulgaria, Burkina Faso, Burundi, Cameroon, Cape Verde, the Central African Republic, Chad, Chile, the People's Republic of China, Colombia, Comoros, the Congo, Costa Rica, Croatia, Cyprus, the Czech Republic, Denmark, Djibouti, Dominica, the Dominican Republic, East Timor, Ecuador, Egypt, El Salvador, Equatorial Guinea, Eritrea, Estonia, Ethiopia, Fiji, Finland, France, French Guiana, Gabon, Gambia, Georgia, Germany, Ghana, Gibraltar, Greece, Grenada, Guadeloupe, Guatemala, Guinea, Guinea-Bissau, Guyana, Haiti, Honduras, Hong Kong, Hungary, Iceland, India, Ireland, Israel, Italy, the Ivory Coast, Jamaica, Jordan, Kazakhstan, Kenya, Kiribati, Kyrgyzstan, Laos, Latvia, Lebanon, Lesotho, Liberia, Liechtenstein, Lithuania, Luxembourg, Macedonia, Madagascar, Malawi, Malaysia, the Maldives, Mali, Malta, the Marshall Islands, Martinique, Mauritania, Mauritius, Mexico, Micronesia, Monaco, Mongolia, Montenegro, Morocco, Mozambique, Namibia, Nauru, Nepal, the Nether Antilles, the Netherlands, New Zealand, Nicaragua, Niger, Nigeria, Norway, Oman, Pakistan, Palau, Panama, Papua New Guinea, Paraguay, Peru, the Philippines, Poland, Portugal, the Republic of Moldova, Romania, Russia, Rwanda, Samoa, San Marino, Sao Tome and Principe, Saudi Arabia, Senegal, Serbia, the Seychelles, Sierra Leone, Singapore, Slovakia, Slovenia, the Solomon Islands, Somalia, South Africa, South Korea, Spain, Sri Lanka, St. Kitts and Nevis, St. Lucia, St. Vincent and the Grenadines, Suriname, Swaziland, Sweden, Switzerland, Taiwan, Tajikistan, Tanzania, Togo, Tonga, Trinidad and Tobago, Tunisia, Turkey, Turkmenistan, Tuvalu, Uganda, Ukraine, the United Arab Emirates, the United Kingdom, Uruguay, Uzbekistan, Vanuatu, Venezuela, Vietnam, Yemen, Zaire, Zambia, and Zimbabwe
507952-001	Intel Core2 Duo T9600 processor (2.8 GHz, 1066-MHz FSB, 6-MB L2 cache)
507954-001	Intel Core2 Duo T9400 processor (2.53 GHz, 1066-MHz FSB, 6-MB L2 cache, 35W)
507960-001	Intel Core2 Duo P8700 processor (2.53 GHz, 1066-MHz FSB, 3-MB L2 cache)
507961-001	Intel Core2 Duo P8600 processor (2.4 GHz, 1066-MHz FSB, 3-MB L2 cache)
507966-001	Intel Core2 Duo P7370 processor (2.0 GHz, 1066-MHz FSB, 3-MB L2 cache) (Only available with Intel WLAN)
510100-001	SPS-MDM, MDC 1.5 GUZZI F
510100-011	SPS-MDM, MDC 1.5 GUZZI F-ANZ
513598-001	Intel Core2 Duo T6570 processor (2.1 GHz, 800-MHz FSB, 2-MB L2 Cache, TJ 100) (not available for Japan. Only available with Intel WLAN or no WLAN)
513599-001	<i>Intel Pentium Dual-Core T4200 processor (2.0 GHz, 800-MHz FSB, 1-MB L2 cache)</i>
518434-001	<i>Broadcom 4322 AGN 802.11a/b/g WLAN module for use in Antigua and Barbuda, Barbados, Belize, Canada, the Cayman Islands, Guam, Puerto Rico, Trinidad and Tobago, the U.S. Virgin Islands, and the United States</i>

<b>Spare part number</b>	<b>Description</b>
518434-002	<i>Broadcom 4322 AGN 802.11a/b/g WLAN module for use in Afghanistan, Albania, Algeria, Andorra, Angola, Antigua and Barbuda, Argentina, Armenia, Aruba, Australia, Austria, Azerbaijan, the Bahamas, Bahrain, Bangladesh, Barbados, Belarus, Belgium, Belize, Benin, Bermuda, Bhutan, Bolivia, Bosnia and Herzegovina, Botswana, Brazil, the British Virgin Islands, Brunei, Bulgaria, Burkina Faso, Burundi, Cameroon, Cape Verde, the Central African Republic, Chad, Chile, the People's Republic of China, Colombia, Comoros, the Congo, Costa Rica, Croatia, Cyprus, the Czech Republic, Denmark, Djibouti, Dominica, the Dominican Republic, East Timor, Ecuador, Egypt, El Salvador, Equatorial Guinea, Eritrea, Estonia, Ethiopia, Fiji, Finland, France, French Guiana, Gabon, Gambia, Georgia, Germany, Ghana, Gibraltar, Greece, Grenada, Guadeloupe, Guatemala, Guinea, Guinea-Bissau, Guyana, Haiti, Honduras, Hong Kong, Hungary, Iceland, India, Ireland, Israel, Italy, the Ivory Coast, Jamaica, Jordan, Kazakhstan, Kenya, Kiribati, Kyrgyzstan, Laos, Latvia, Lebanon, Lesotho, Liberia, Liechtenstein, Lithuania, Luxembourg, Macedonia, Madagascar, Malawi, Malaysia, the Maldives, Mali, Malta, the Marshall Islands, Martinique, Mauritania, Mauritius, Mexico, Micronesia, Monaco, Mongolia, Montenegro, Morocco, Mozambique, Namibia, Nauru, Nepal, the Nether Antilles, the Netherlands, New Zealand, Nicaragua, Niger, Nigeria, Norway, Oman, Pakistan, Palau, Panama, Papua New Guinea, Paraguay, Peru, the Philippines, Poland, Portugal, the Republic of Moldova, Romania, Russia, Rwanda, Samoa, San Marino, Sao Tome and Principe, Saudi Arabia, Senegal, Serbia, the Seychelles, Sierra Leone, Singapore, Slovakia, Slovenia, the Solomon Islands, Somalia, South Africa, South Korea, Spain, Sri Lanka, St. Kitts and Nevis, St. Lucia, St. Vincent and the Grenadines, Suriname, Swaziland, Sweden, Switzerland, Taiwan, Tajikistan, Tanzania, Togo, Tonga, Trinidad and Tobago, Tunisia, Turkey, Turkmenistan, Tuvalu, Uganda, Ukraine, the United Arab Emirates, the United Kingdom, Uruguay, Uzbekistan, Vanuatu, Venezuela, Vietnam, Yemen, Zaire, Zambia, and Zimbabwe</i>
519898-001	Intel Celeron 585 processor (2.16 GHz, 800-MHz FSB, 2-MB L2 cache)
532324-001	Intel Celeron Dual-Core T1600 processor (1.66GHz, 667-MHz FSB, 1-MB L2 cache)
534084-001	Intel Celeron Dual-Core T1700 processor (1.83-GHz, 667-MHz FSB, 1-MB L2 cache)
534419-001	Intel Celeron 900 processor (2.20 GHz, 800-MHz FSB, 1-MB L2 cache)
535593-001	90-W Smart AC adapter (for use only in India)
535752-001	Base enclosure (includes rubber feet)
535753-001	8-cell, 63-Wh Li-ion battery
535754-001	Battery board connector
535755-001	Optical disk drive connector board
535757-001	Display Cable Kit (includes microphone, wireless antenna, display panel, and webcam cables)
535758-001	Switch cover
535759-001	Blu-ray ROM with LightScribe DVD±RW SuperMulti DL Drive
535760-001	DVD ROM Drive
535761-001	DVD±RW and CD-RW SuperMulti Double-Layer Combo Drive with LightScribe
535762-001	160-GB, 5400-rpm hard drive
535763-001	250-GB, 5400-rpm hard drive
535764-001	320-GB, 5400-rpm hard drive
535765-001	500-GB, 5400-rpm hard drive
535766-001	Broadcom Bluetooth module
535767-001	Heat sink (includes replacement thermal material)
535768-001	Display enclosure
535769-001	Display bezel with webcam



<b>Spare part number</b>	<b>Description</b>
535770-001	Display bezel without a webcam
535771-001	Display Cable Kit
535772-001	Display hinge
535773-001	1-GB memory module (PC2-6400, 800-MHz, DDR2)
535774-001	2-GB memory module (PC2-6400, 800-MHz, DDR2)
535775-001	Palm rest with TouchPad
535776-001	17.3-inch, HD+ display assembly
535777-001	17.3-inch, HD+ BrightView display assembly with camera
535778-001	17.3-inch, HD+ display assembly with camera
535779-001	17.3-inch, HD+ BrightView display assembly
535780-001	Plastics Kit (includes ExpressCard slot bezel and optical drive bezel)
535793-001	Rubber Kit
535794-001	Screw Kit
535795-001	Speaker Kit
535796-001	Top cover
535797-001	Webcam module
535798-001	Keyboard for use in the United States
535798-031	Keyboard for use in the United Kingdom
535798-041	Keyboard for use in Germany
535798-051	Keyboard for use in France
535798-061	Keyboard for use in Italy
535798-071	Keyboard for use in Spain
535798-081	Keyboard for use in Denmark
535798-091	Keyboard for use in Norway
535798-121	Keyboard for use in French Canada
535798-131	Keyboard for use in Portugal
535798-141	Keyboard for use in Turkey
535798-161	Keyboard for use in Latin America
535798-171	Keyboard for use in Arabia
535798-201	Keyboard for use in Brazil
535798-211	Keyboard for use in Hungary
535798-221	Keyboard for use in Czech Republic
535798-231	Keyboard for use in Slovakia

<b>Spare part number</b>	<b>Description</b>
535798-251	Keyboard for use in Russia
535798-261	Keyboard for use in Bulgaria
535798-281	Keyboard for use in Thailand
535798-291	Keyboard for use in Japan
535798-A41	Keyboard for use in Europe A4
535798-AB1	Keyboard for use in Taiwan
535798-AD1	Keyboard for use in South Korea
535798-B31	Keyboard for use in Europe
535798-B71	Keyboard for use in Sweden/Finland
535798-BB1	Keyboard for use in Israel
535798-BG1	Keyboard for use in Switzerland
535798-DD1	Keyboard for use in Iceland
535798-DJ1	Keyboard for use in Greece
535835-001	Intel Core2 Duo T5870 processor (2.0 GHz, 800-MHz FSB, 2-MB L2 cache)
537921-001	<i>HP Integrated Bluetooth 2.1 module for use in all countries and regions except Japan and Asia Pacific countries and regions</i>
572520-001	<i>Intel Wi-Fi Link 1000, 802.11b/g/n WLAN module for use in Andorra, Antigua and Barbuda, Argentina, Aruba, Australia, Austria, Azerbaijan, the Bahamas, Barbados, Belgium, Bolivia, Bosnia and Herzegovina, Brazil, Brunei, Bulgaria, Canada, Cayman Islands, Chile, China, Colombia, Costa Rica, Croatia, Cyprus, the Czech Republic, Denmark, the Dominican Republic, Ecuador, Egypt, El Salvador, Estonia, Finland, France, French Guiana, Guadeloupe, Guam, Georgia, Germany, Ghana, Greece, Guatemala, Haiti, Honduras, Hong Kong, Hungary, Iceland, India, Indonesia, Ireland, Israel, Italy, Ivory Coast, Jamaica, Japan, Jordan, Kenya, Kuwait, Kyrgyzstan, Latvia, Lebanon, Liechtenstein, Lithuania, Luxembourg, Malawi, Malaysia, Malta, Martinique, Mauritius, Mexico, Monaco, Montenegro, Morocco, the Nether Antilles, the Netherlands, New Zealand, Nicaragua, Nigeria, Oman, Pakistan, Panama, Paraguay, Peru, the Philippines, Poland, Portugal, Puerto Rico, Qatar, Romania, San Marino, Saudi Arabia, Senegal, Singapore, Slovakia, Slovenia, South Africa, South Korea, Spain, Sri Lanka, Sweden, Switzerland, Taiwan, Tanzania, Thailand, Trinidad and Tobago, Turkey, United Arab Emirates, the United Kingdom, the United States, Uruguay, the U.S. Virgin Islands, Venezuela, and Vietnam</i>
572816-001	160-GB, 7200-rpm hard drive
572817-001	250-GB, 7200-rpm hard drive
572925-001	Intel Celeron Dual-Core T3100 processor (1.9-GHz, 800-MHz FSB, 1-MB L2 cache)
572926-001	Intel Celeron Dual-Core T3000 processor (1.8-GHz, 800-MHz FSB, 1-MB L2 cache)
572927-001	Intel Core2 Duo T6670 processor (2.2 GHz, 800-MHz FSB, 2-MB L2 cache)
572929-001	Intel Pentium Dual-Core T4300 processor (2.16 GHz, 800-MHz FSB, 1-MB L2 cache)
572930-001	Intel Core2 Duo P7570 processor (2.26 GHz, 1066-MHz FSB, 3-MB L2 cache)
574493-001	Power button board (includes cable)
574508-001	System board for use in computers with DDR2 memory (includes replacement thermal material and the ExpressCard assembly)
574719-001	320-GB, 7200-rpm hard drive

<b>Spare part number</b>	<b>Description</b>
<i>574720-001</i>	<i>500-GB, 7200-rpm hard drive</i>
<i>583073-001</i>	<i>1-GB memory module (PC3-10600, 1333-MHz, DDR3)</i>
<i>583074-001</i>	<i>2-GB memory module (PC3-10600, 1333-MHz, DDR3)</i>
<i>583077-001</i>	<i>System board for use in computers with DDR3 memory (includes replacement thermal material and the ExpressCard assembly)</i>
<i>585984-001</i>	<i>Intel Wi-Fi Link 1000, 802.11b/g WLAN module for use in Russia and Ukraine</i>

---

# 4 Removal and replacement procedures

## Preliminary replacement requirements

### Tools required

You will need the following tools to complete the removal and replacement procedures:

- Flat-bladed screwdriver
- Magnetic screwdriver
- Torx T8 screwdriver
- Phillips P0 and P1 screwdrivers

### Service considerations

The following sections include some of the considerations that you must keep in mind during disassembly and assembly procedures.

---

 **NOTE:** As you remove each subassembly from the computer, place the subassembly (and all accompanying screws) away from the work area to prevent damage.

---

### Plastic parts

---

 **CAUTION:** Using excessive force during disassembly and reassembly can damage plastic parts. Use care when handling the plastic parts. Apply pressure only at the points designated in the maintenance instructions.

---

## Cables and connectors

- 
- △ **CAUTION:** When servicing the computer, be sure that cables are placed in their proper locations during the reassembly process. Improper cable placement can damage the computer.
- 

Cables must be handled with extreme care to avoid damage. Apply only the tension required to unseat or seat the cables during removal and insertion. Handle cables by the connector whenever possible. In all cases, avoid bending, twisting, or tearing cables. Be sure that cables are routed in such a way that they cannot be caught or snagged by parts being removed or replaced. Handle flex cables with extreme care; these cables tear easily.

## Drive handling

- 
- △ **CAUTION:** Drives are fragile components that must be handled with care. To prevent damage to the computer, damage to a drive, or loss of information, observe these precautions:
- 

Before removing or inserting a hard drive, shut down the computer. If you are unsure whether the computer is off or in Hibernation, turn the computer on, and then shut it down through the operating system.

Before handling a drive, be sure that you are discharged of static electricity. While handling a drive, avoid touching the connector.

Before removing a diskette drive or optical drive, be sure that a diskette or disc is not in the drive and be sure that the optical drive tray is closed.

Handle drives on surfaces covered with at least one inch of shock-proof foam.

Avoid dropping drives from any height onto any surface.

After removing a hard drive, an optical drive, or a diskette drive, place it in a static-proof bag.

Avoid exposing a hard drive to products that have magnetic fields, such as monitors or speakers.

Avoid exposing a drive to temperature extremes or liquids.

If a drive must be mailed, place the drive in a bubble pack mailer or other suitable form of protective packaging and label the package "FRAGILE."

---

## Grounding guidelines

### Electrostatic discharge damage

Electronic components are sensitive to electrostatic discharge (ESD). Circuitry design and structure determine the degree of sensitivity. Networks built into many integrated circuits provide some protection, but in many cases, ESD contains enough power to alter device parameters or melt silicon junctions.

A discharge of static electricity from a finger or other conductor can destroy static-sensitive devices or microcircuitry. Even if the spark is neither felt nor heard, damage may have occurred.

An electronic device exposed to ESD may not be affected at all and can work perfectly throughout a normal cycle. Or the device may function normally for a while, then degrade in the internal layers, reducing its life expectancy.

- △ **CAUTION:** To prevent damage to the computer when you are removing or installing internal components, observe these precautions:

Keep components in their electrostatic-safe containers until you are ready to install them.

Use nonmagnetic tools.

Before touching an electronic component, discharge static electricity by using the guidelines described in this section.

Avoid touching pins, leads, and circuitry. Handle electronic components as little as possible.

If you remove a component, place it in an electrostatic-safe container.

The following table shows how humidity affects the electrostatic voltage levels generated by different activities.

- △ **CAUTION:** A product can be degraded by as little as 700 V.

Typical electrostatic voltage levels			
Event	Relative humidity		
	10%	40%	55%
Walking across carpet	35,000 V	15,000 V	7,500 V
Walking across vinyl floor	12,000 V	5,000 V	3,000 V
Motions of bench worker	6,000 V	800 V	400 V
Removing DIPS from plastic tube	2,000 V	700 V	400 V
Removing DIPS from vinyl tray	11,500 V	4,000 V	2,000 V
Removing DIPS from Styrofoam	14,500 V	5,000 V	3,500 V
Removing bubble pack from PCB	26,500 V	20,000 V	7,000 V
Packing PCBs in foam-lined box	21,000 V	11,000 V	5,000 V

## Packaging and transporting guidelines

Follow these grounding guidelines when packaging and transporting equipment:

- To avoid hand contact, transport products in static-safe tubes, bags, or boxes.
- Protect ESD-sensitive parts and assemblies with conductive or approved containers or packaging.
- Keep ESD-sensitive parts in their containers until the parts arrive at static-free workstations.
- Place items on a grounded surface before removing items from their containers.
- Always be properly grounded when touching a component or assembly.
- Store reusable ESD-sensitive parts from assemblies in protective packaging or nonconductive foam.
- Use transporters and conveyors made of antistatic belts and roller bushings. Be sure that mechanized equipment used for moving materials is wired to ground and that proper materials are selected to avoid static charging. When grounding is not possible, use an ionizer to dissipate electric charges.

## Workstation guidelines

Follow these grounding workstation guidelines:

- Cover the workstation with approved static-shielding material.
- Use a wrist strap connected to a properly grounded work surface and use properly grounded tools and equipment.
- Use conductive field service tools, such as cutters, screwdrivers, and vacuums.
- When fixtures must directly contact dissipative surfaces, use fixtures made only of static-safe materials.
- Keep the work area free of nonconductive materials, such as ordinary plastic assembly aids and Styrofoam.
- Handle ESD-sensitive components, parts, and assemblies by the case or PCM laminate. Handle these items only at static-free workstations.
- Avoid contact with pins, leads, or circuitry.
- Turn off power and input signals before inserting or removing connectors or test equipment.

## Equipment guidelines

Grounding equipment must include either a wrist strap or a foot strap at a grounded workstation.

- When seated, wear a wrist strap connected to a grounded system. Wrist straps are flexible straps with a minimum of one megohm  $\pm 10\%$  resistance in the ground cords. To provide proper ground, wear a strap snugly against the skin at all times. On grounded mats with banana-plug connectors, use alligator clips to connect a wrist strap.
- When standing, use foot straps and a grounded floor mat. Foot straps (heel, toe, or boot straps) can be used at standing workstations and are compatible with most types of shoes or boots. On conductive floors or dissipative floor mats, use foot straps on both feet with a minimum of one megohm resistance between the operator and ground. To be effective, the conductive strips must be worn in contact with the skin.

The following grounding equipment is recommended to prevent electrostatic damage:

- Antistatic tape
- Antistatic smocks, aprons, and sleeve protectors
- Conductive bins and other assembly or soldering aids
- Nonconductive foam
- Conductive tabletop workstations with ground cords of one megohm resistance
- Static-dissipative tables or floor mats with hard ties to the ground
- Field service kits
- Static awareness labels
- Material-handling packages
- Nonconductive plastic bags, tubes, or boxes
- Metal tote boxes
- Electrostatic voltage levels and protective materials

The following table lists the shielding protection provided by antistatic bags and floor mats.

Material	Use	Voltage protection level
Antistatic plastic	Bags	1,500 V
Carbon-loaded plastic	Floor mats	7,500 V
Metallized laminate	Floor mats	5,000 V



# Component replacement procedures

This section provides removal and replacement procedures.

There are as many as 89 screws, in 15 different sizes, that must be removed, replaced, or loosened when servicing the computer. Make special note of each screw size and location during removal and replacement.

## Service tag

The service tag, affixed to the bottom of the computer, provides information that may be needed when troubleshooting system problems. The service tag provides the following information:

- (1) Product name: This is the product name affixed to the front of the computer.
- (2) Serial number (s/n): This is an alphanumeric identifier that is unique to each product.
- (3) Part number/Product number (p/n): This number provides specific information about the product's hardware components. The part number helps a service technician to determine what components and parts are needed.
- (4) Model description: This is the alphanumeric identifier used to locate documents, drivers, and support for the computer.
- (5) Warranty period: Describes the duration of the warranty period for this computer.



## Computer feet

The computer feet are adhesive-backed rubber pads. The feet are included in the Rubber Kit, spare part number 535793-001. There are 7 rubber feet that attach to the base enclosure in the locations illustrated below.

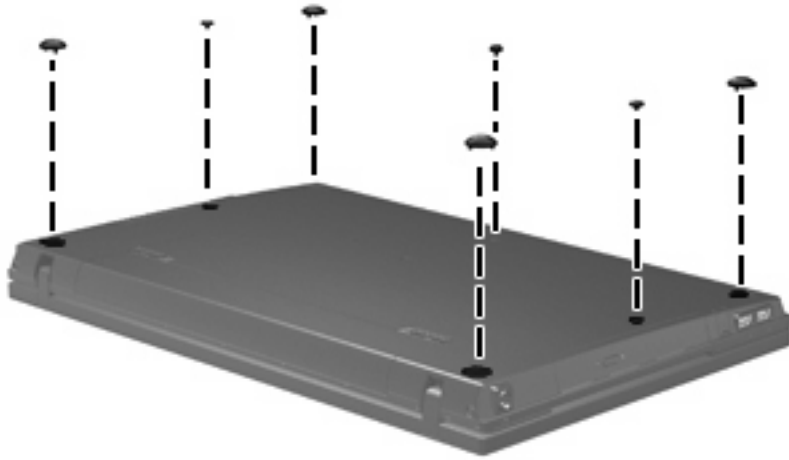

## Battery

Description	Spare part number
8-cell, 63-Wh Li-ion battery	535753-001

Before disassembling the computer, follow these steps:

1. Shut down the computer. If you are unsure whether the computer is off or in Hibernation, turn the computer on, and then shut it down through the operating system.
2. Disconnect all external devices connected to the computer.
3. Disconnect the power from the computer by first unplugging the power cord from the AC outlet and then unplugging the AC adapter from the computer.

Remove the battery:

1. Turn the computer upside down on a flat surface, with the battery bay toward you.
2. Slide the battery release latches (1) to release the battery.
3. Remove the battery (2) from the computer.

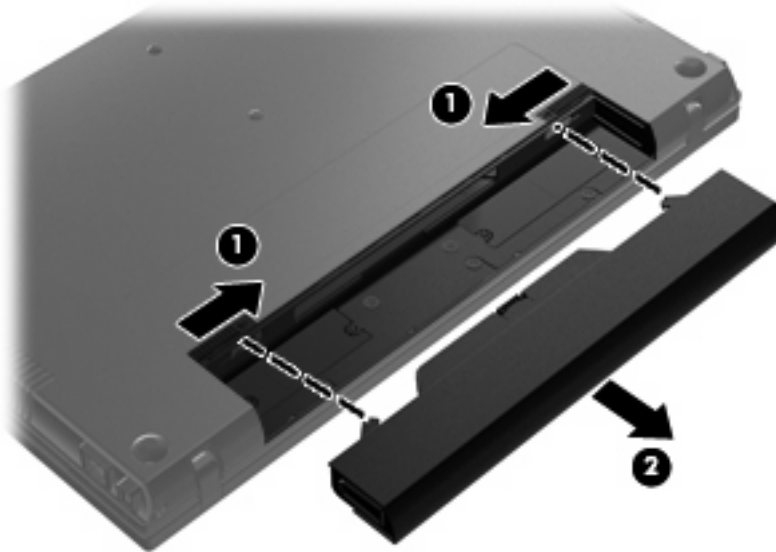

Install the battery by inserting it into the battery bay until you hear a click.

## Switch cover and keyboard

Description		Spare part number	
<b>Switch cover</b>		535758-001	
<b>Keyboards for use in the following countries or regions:</b>			
Arabia	535798-171	Japan	535798-291
Brazil	535798-201	Latin America	535798-161
Bulgaria	535798-261	Norway	535798-091
Czech Republic	535798-221	Portugal	535798-131
Denmark	535798-081	Russia	535798-251
Europe	535798-B31	Slovakia	535798-231
Europe A4	535798-A41	South Korea	535798-AD1
France	535798-051	Spain	535798-071
French Canada	535798-121	Sweden/Finland	535798-B71
Germany	535798-041	Switzerland	535798-BG1
Greece	535798-DJ1	Taiwan	535798-AB1
Hungary	535798-211	Thailand	535798-281
Iceland	535798-DD1	Turkey	535798-141
Israel	535798-BB1	United Kingdom	535798-031
Italy	535798-061	The United States	535798-001

Before removing the switch cover and keyboard, follow these steps:

1. Shut down the computer. If you are unsure whether the computer is off or in Hibernation, turn the computer on, and then shut it down through the operating system.
2. Disconnect all external devices connected to the computer.
3. Disconnect the power from the computer by first unplugging the power cord from the AC outlet and then unplugging the AC adapter from the computer.
4. Remove the battery (see [Battery on page 41](#)).

Remove the switch cover and keyboard:

1. Remove the following screws:
  - (1) Two screw covers and two Phillips PM2.5×3.0 screws
  - (2) Three Phillips PM2.0×3.0 broadhead screws
  - (3) Two Phillips PM2.0×3.0 screws

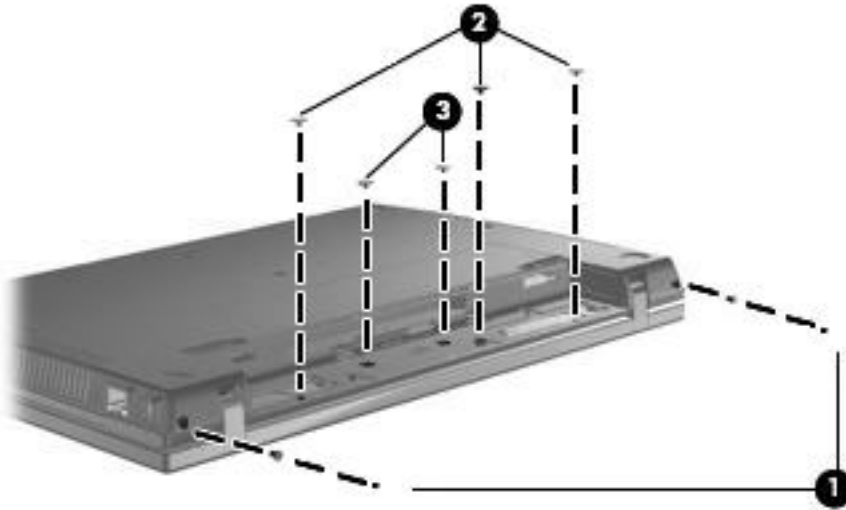

2. Turn the computer right-side up, with the front toward you.
3. Open the computer as far as possible.
4. Slide the switch cover back (1) and lift it straight up (2) until it disengages from the computer.

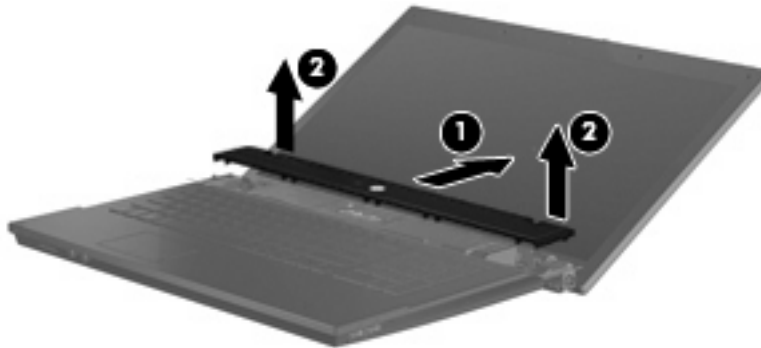

5. Remove the two PM2.5×4.5 screws that secure the keyboard to the computer.



6. Slide the keyboard back (1), and rotate it forward (2) until it rests on the base enclosure.



7. Release the zero insertion force (ZIF) connector (1) to which the keyboard cable is attached, and disconnect the keyboard cable (2) from the system board.

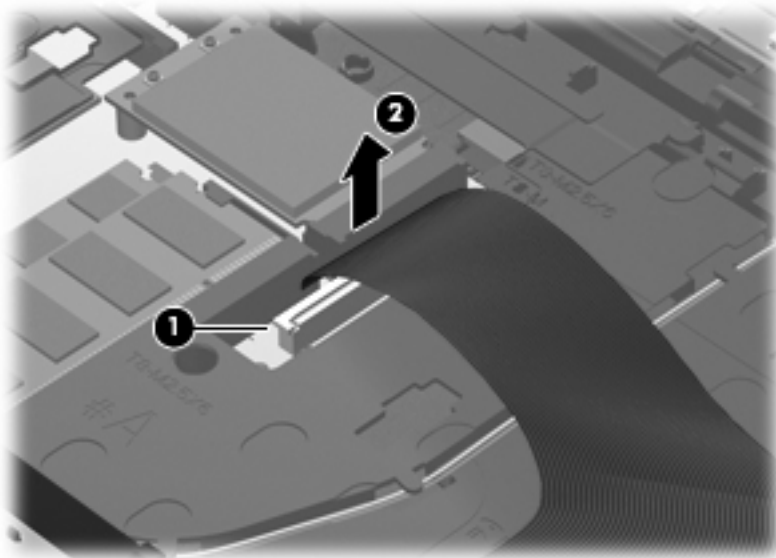

8. Remove the keyboard.

Reverse this procedure to install the switch cover and keyboard.

## Memory module

 **NOTE:** Older models use DDR2 memory, while newer models use DDR3 memory. You cannot use model numbers to determine the type of memory a model uses.

**NOTE:** When adding a second memory module, be sure it is the same type and speed as the installed memory module. DDR2 memory modules cannot be mixed with DDR3 memory modules.

Description	Spare part number
<i>For use in models that use DDR2 memory</i>	
2-GB (PC2-6400, 800-MHz, DDR2)	535774-001
1-GB (PC2-6400, 800-MHz, DDR2)	535773-001
<i>For use in models that use DDR3 memory</i>	
2-GB (PC3-10600, 1333-MHz, DDR3)	583074-001
1-GB (PC3-10600, 1333-MHz, DDR3)	583073-001

Before removing the memory module, follow these steps:

1. Shut down the computer. If you are unsure whether the computer is off or in Hibernation, turn the computer on, and then shut it down through the operating system.
2. Disconnect all external devices connected to the computer.
3. Disconnect the power from the computer by first unplugging the power cord from the AC outlet and then unplugging the AC adapter from the computer.
4. Remove the battery (see [Battery on page 41](#)).
5. Remove the switch cover and keyboard (see [Switch cover and keyboard on page 42](#)).

Remove the memory module:

1. Position the computer with the front toward you.
2. Spread the retaining tabs **(1)** on each side of the memory module slot to release the memory module. (The edge of the module opposite the slot rises away from the computer.)

3. Remove the memory module (2) by pulling the module away from the slot at an angle.

 **NOTE:** Memory modules are designed with a notch (3) to prevent incorrect insertion into the memory module slot.

---

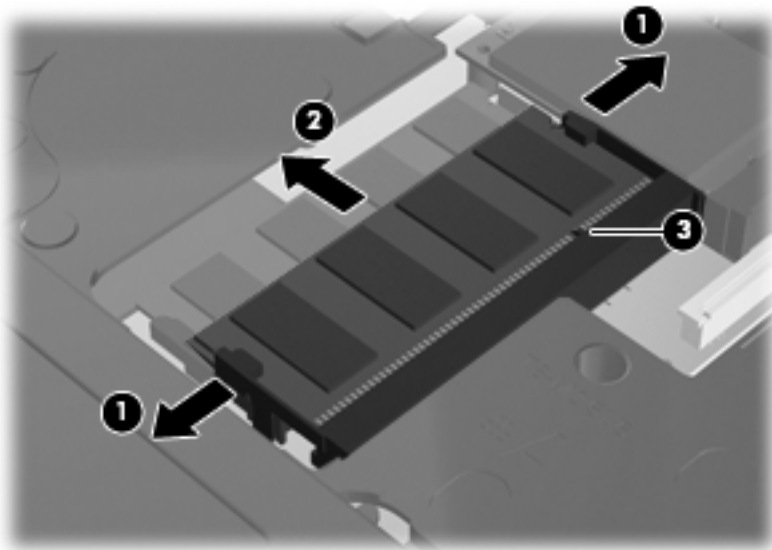

Reverse this procedure to install a memory module.



## Optical drive

 **NOTE:** All optical drive spare part kits include an optical drive bezel.

Description	Spare part number
DVD±RW and CD-RW SuperMulti Double-Layer Combo Drive with LightScribe	535761-001
Blu-ray ROM with LightScribe DVD±RW SuperMulti DL Drive	535759-001
DVD-ROM Drive	535760-001

Before removing the optical drive, follow these steps:

1. Shut down the computer. If you are unsure whether the computer is off or in Hibernation, turn the computer on, and then shut it down through the operating system.
2. Disconnect all external devices connected to the computer.
3. Disconnect the power from the computer by first unplugging the power cord from the AC outlet and then unplugging the AC adapter from the computer.
4. Remove the battery (see [Battery on page 41](#)).
5. Remove the switch cover and keyboard (see [Switch cover and keyboard on page 42](#)).

Remove the optical drive:

1. Position the computer with the front toward you.
2. Remove the slotted PM2.5×4.5 screw (1) that secures the optical drive to the computer.
3. Insert a flat-bladed screwdriver or similar tool into the optical drive tab access (2) and press the tab to the left to release the optical drive from the computer.
4. Remove the optical drive (3) from the computer.

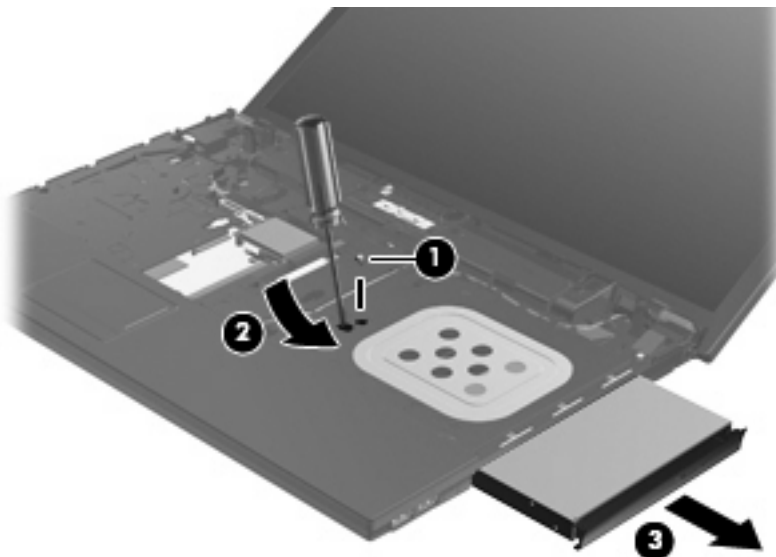

5. If it is necessary to replace the optical drive bracket, position the optical drive with the rear toward you.
6. Remove the two Phillips PM2.0×3.0 screws (1) that secure the optical drive bracket to the optical drive.
7. Remove the optical drive bracket (2).

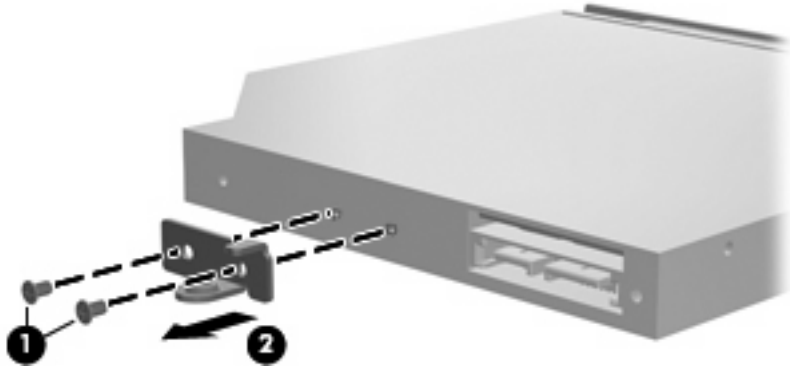

Reverse this procedure to reassemble and install an optical drive.

## Speakers

Description	Spare part number
Speaker Kit	535795-001

Before removing the speakers, follow these steps:

1. Shut down the computer. If you are unsure whether the computer is off or in Hibernation, turn the computer on, and then shut it down through the operating system.
2. Disconnect all external devices connected to the computer.
3. Disconnect the power from the computer by first unplugging the power cord from the AC outlet and then unplugging the AC adapter from the computer.
4. Remove the battery (see [Battery on page 41](#)).
5. Remove the switch cover and keyboard (see [Switch cover and keyboard on page 42](#)).

Remove the speakers:

1. Disconnect the speaker cable (1) from the system board and remove the speaker cable from the clips and routing channel.

 **NOTE:** The two speakers are connected with a single cable.

2. Remove the four PM2.5×3.0 screws (2) that secure the speakers to the computer.
3. Remove the speakers (3) from the computer.

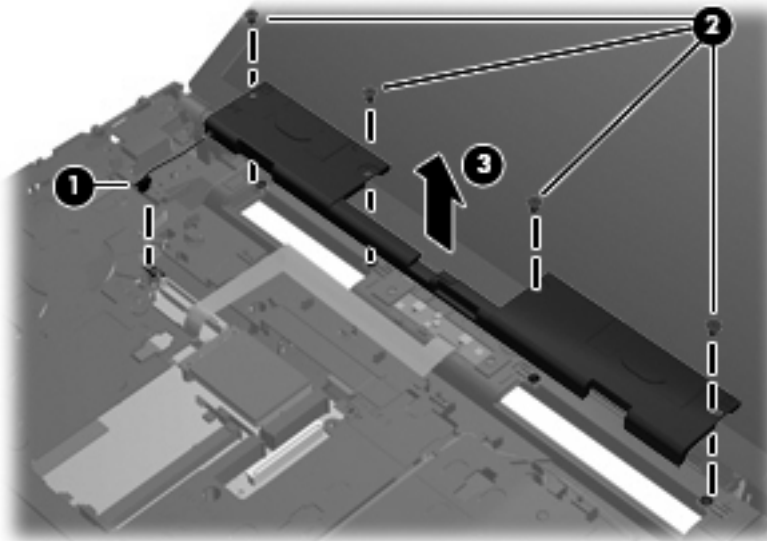

Reverse this procedure to install the speakers.

## Palm rest

Description	Spare part number
Palm rest (includes TouchPad)	535775-001

Before removing the palm rest, follow these steps:

1. Shut down the computer. If you are unsure whether the computer is off or in Hibernation, turn the computer on, and then shut it down through the operating system.
2. Disconnect all external devices connected to the computer.
3. Disconnect the power from the computer by first unplugging the power cord from the AC outlet and then unplugging the AC adapter from the computer.
4. Remove the battery (see [Battery on page 41](#))
5. Remove the switch cover and keyboard (see [Switch cover and keyboard on page 42](#))

Remove the palm rest:

1. Remove the three Phillips PM2.0×3.0 broadhead screws (1) from the system board.
2. Slide the palm rest back (2), then lift and rotate the front edge until the palm rest rests on the system board (3).

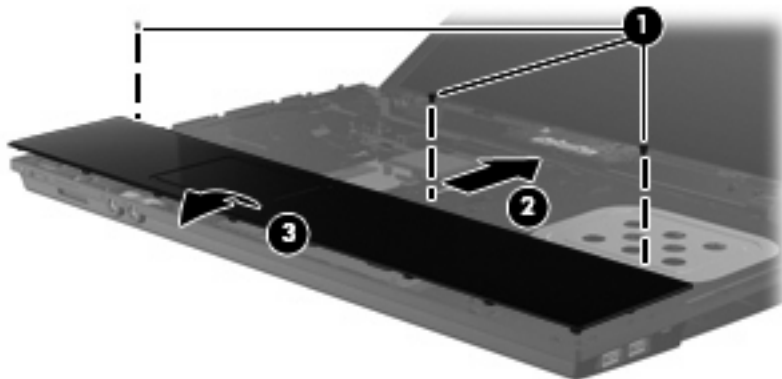

3. Release the ZIF connector (1) to which the TouchPad cable is connected, and then disconnect the TouchPad cable (2) from the system board.

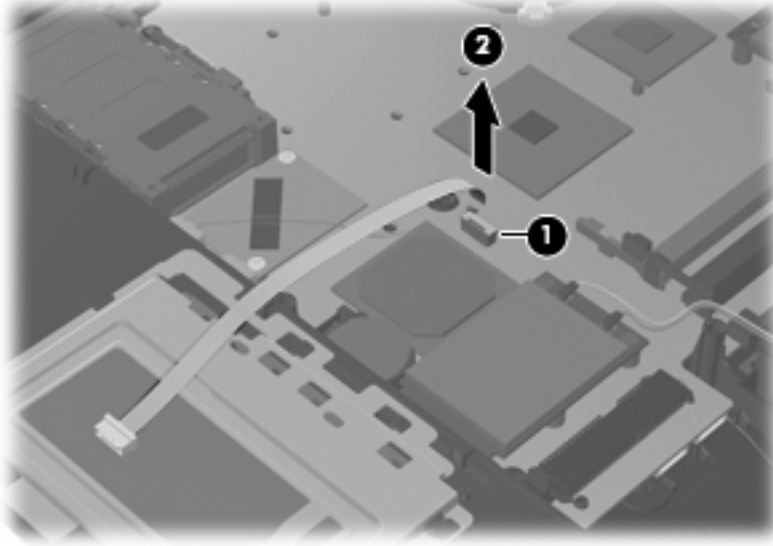

4. Remove the palm rest.

Reverse this procedure to install the palm rest.

## Hard drive

 **NOTE:** All hard drive spare part kits include a hard drive bracket.

Description	Spare part number
500-GB, 7200-rpm hard drive	574720-001
500-GB, 5400-rpm hard drive	535765-001
320-GB, 7200-rpm hard drive	574719-001
320-GB, 5400-rpm hard drive	535764-001
250-GB, 7200-rpm hard drive	572817-001
250-GB, 5400-rpm hard drive	535763-001
160-GB, 7200-rpm hard drive	572816-001
160-GB, 5400-rpm hard drive	535762-001

Before removing the hard drive, follow these steps:

1. Shut down the computer. If you are unsure whether the computer is off or in Hibernation, turn the computer on, and then shut it down through the operating system.
2. Disconnect all external devices connected to the computer.
3. Disconnect the power from the computer by first unplugging the power cord from the AC outlet and then unplugging the AC adapter from the computer.
4. Remove the battery (see [Battery on page 41](#)).
5. Remove the switch cover and keyboard (see [Switch cover and keyboard on page 42](#)).
6. Remove the palm rest (see [Palm rest on page 50](#)).

Remove the hard drive:

1. Position the computer with the front toward you.
2. Loosen the two Phillips PM2.0×4.0 screws **(1)** that secure the hard drive to the computer.
3. Loosen the Phillips PM2.5×10.0 captive screw **(2)** that secures the hard drive to the computer.
4. Grasp the Mylar tab **(3)** on the hard drive and slide the hard drive to the right to disconnect it from the system board.

5. Remove the hard drive (4) from the hard drive bay.

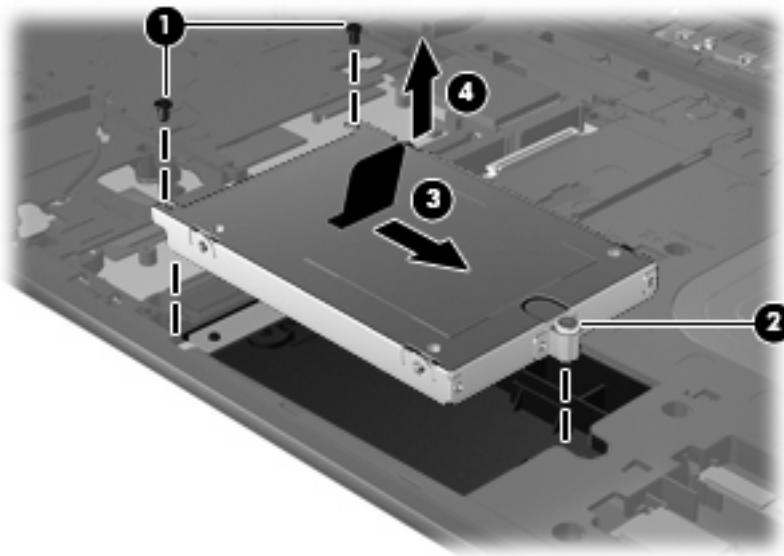

6. If it is necessary to replace the hard drive bracket, remove the two Phillips PM3.0×4.0 hard drive bracket screws (1) from each side of the hard drive.
7. Lift the bracket (2) straight up to remove it from the hard drive.

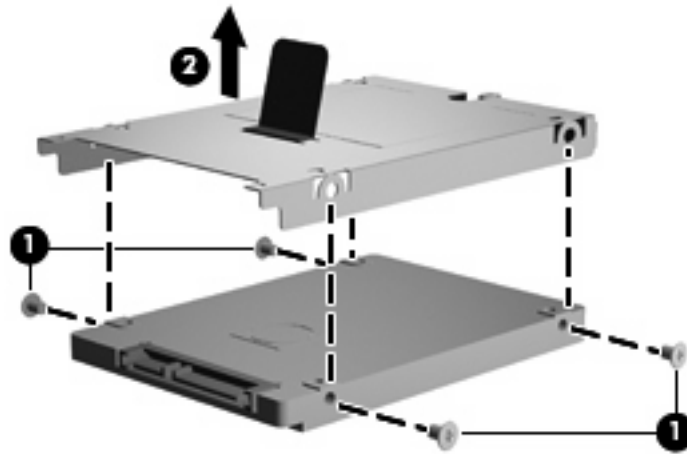

Reverse this procedure to reassemble and install the hard drive.

## Bluetooth module

 **NOTE:** The Bluetooth module spare part kit does not include a Bluetooth module cable. The Bluetooth module cable is included in the Cable Kit, spare part number 535757-001.

Description	Spare part number
<i>Bluetooth 2.0 module</i>	398393-002
<i>Bluetooth 2.1 module</i>	537921-001

Before removing the Bluetooth module, follow these steps:

1. Shut down the computer. If you are unsure whether the computer is off or in Hibernation, turn the computer on, and then shut it down through the operating system.
2. Disconnect all external devices connected to the computer.
3. Disconnect the power from the computer by first unplugging the power cord from the AC outlet and then unplugging the AC adapter from the computer.
4. Remove the battery (see [Battery on page 41](#)).
5. Remove the following components:
  - a. Switch cover and keyboard (see [Switch cover and keyboard on page 42](#))
  - b. Palm rest (see [Palm rest on page 50](#))
  - c. Hard drive (see [Hard drive on page 52](#))

Remove the Bluetooth module:

1. Disconnect the Bluetooth module cable (1) from the system board.
2. Remove the Bluetooth module cable (2) from the routing path.
3. Remove the Bluetooth module from the clip (3) that secures it to the base enclosure.

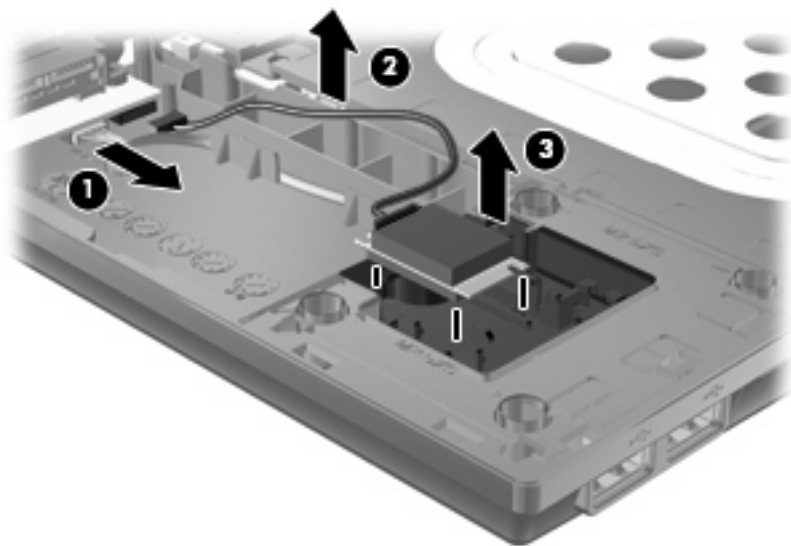



Reverse this procedure to install the Bluetooth module.

## WLAN module

Description	Spare part number
<b>Broadcom 802.11a/b/g/n WLAN modules:</b>	
<ul style="list-style-type: none"> <li>Broadcom 4322 802.11a/b/g/n WLAN module for use in Antigua and Barbuda, Barbados, Belize, Canada, the Cayman Islands, Guam, Puerto Rico, Trinidad and Tobago, the U.S. Virgin Islands, and the United States</li> </ul>	504664-001
<ul style="list-style-type: none"> <li>Broadcom 4322 802.11a/b/g/n WLAN module for use in Afghanistan, Albania, Algeria, Andorra, Angola, Antigua and Barbuda, Argentina, Armenia, Aruba, Australia, Austria, Azerbaijan, the Bahamas, Bahrain, Bangladesh, Barbados, Belarus, Belgium, Belize, Benin, Bermuda, Bhutan, Bolivia, Bosnia and Herzegovina, Botswana, Brazil, the British Virgin Islands, Brunei, Bulgaria, Burkina Faso, Burundi, Cameroon, Cape Verde, the Central African Republic, Chad, Chile, the People's Republic of China, Colombia, Comoros, the Congo, Costa Rica, Croatia, Cyprus, the Czech Republic, Denmark, Djibouti, Dominica, the Dominican Republic, East Timor, Ecuador, Egypt, El Salvador, Equatorial Guinea, Eritrea, Estonia, Ethiopia, Fiji, Finland, France, French Guiana, Gabon, Gambia, Georgia, Germany, Ghana, Gibraltar, Greece, Grenada, Guadeloupe, Guatemala, Guinea, Guinea-Bissau, Guyana, Haiti, Honduras, Hong Kong, Hungary, Iceland, India, Ireland, Israel, Italy, the Ivory Coast, Jamaica, Jordan, Kazakhstan, Kenya, Kiribati, Kyrgyzstan, Laos, Latvia, Lebanon, Lesotho, Liberia, Liechtenstein, Lithuania, Luxembourg, Macedonia, Madagascar, Malawi, Malaysia, the Maldives, Mali, Malta, the Marshall Islands, Martinique, Mauritania, Mauritius, Mexico, Micronesia, Monaco, Mongolia, Montenegro, Morocco, Mozambique, Namibia, Nauru, Nepal, the Nether Antilles, the Netherlands, New Zealand, Nicaragua, Niger, Nigeria, Norway, Oman, Pakistan, Palau, Panama, Papua New Guinea, Paraguay, Peru, the Philippines, Poland, Portugal, the Republic of Moldova, Romania, Russia, Rwanda, Samoa, San Marino, Sao Tome and Principe, Saudi Arabia, Senegal, Serbia, the Seychelles, Sierra Leone, Singapore, Slovakia, Slovenia, the Solomon Islands, Somalia, South Africa, South Korea, Spain, Sri Lanka, St. Kitts and Nevis, St. Lucia, St. Vincent and the Grenadines, Suriname, Swaziland, Sweden, Switzerland, Taiwan, Tajikistan, Tanzania, Togo, Tonga, Trinidad and Tobago, Tunisia, Turkey, Turkmenistan, Tuvalu, Uganda, Ukraine, the United Arab Emirates, the United Kingdom, Uruguay, Uzbekistan, Vanuatu, Venezuela, Vietnam, Yemen, Zaire, Zambia, and Zimbabwe</li> </ul>	504664-002
<b>Broadcom BCM4312 802.11/b/g WLAN modules:</b>	
<ul style="list-style-type: none"> <li>For use in Antigua and Barbuda, Barbados, Belize, Canada, the Cayman Islands, Guam, Puerto Rico, Trinidad and Tobago, the U.S. Virgin Islands, and the United States</li> </ul>	504593-003

Description	Spare part number
<ul style="list-style-type: none"> <li>For use in Afghanistan, Albania, Algeria, Andorra, Angola, Antigua and Barbuda, Argentina, Armenia, Aruba, Australia, Austria, Azerbaijan, the Bahamas, Bahrain, Bangladesh, Barbados, Belarus, Belgium, Belize, Benin, Bermuda, Bhutan, Bolivia, Bosnia and Herzegovina, Botswana, Brazil, the British Virgin Islands, Brunei, Bulgaria, Burkina Faso, Burundi, Cameroon, Cape Verde, the Central African Republic, Chad, Chile, the People's Republic of China, Colombia, Comoros, the Congo, Costa Rica, Croatia, Cyprus, the Czech Republic, Denmark, Djibouti, Dominica, the Dominican Republic, East Timor, Ecuador, Egypt, El Salvador, Equatorial Guinea, Eritrea, Estonia, Ethiopia, Fiji, Finland, France, French Guiana, Gabon, Gambia, Georgia, Germany, Ghana, Gibraltar, Greece, Grenada, Guadeloupe, Guatemala, Guinea, Guinea-Bissau, Guyana, Haiti, Honduras, Hong Kong, Hungary, Iceland, India, Ireland, Israel, Italy, the Ivory Coast, Jamaica, Jordan, Kazakhstan, Kenya, Kiribati, Kyrgyzstan, Laos, Latvia, Lebanon, Lesotho, Liberia, Liechtenstein, Lithuania, Luxembourg, Macedonia, Madagascar, Malawi, Malaysia, the Maldives, Mali, Malta, the Marshall Islands, Martinique, Mauritania, Mauritius, Mexico, Micronesia, Monaco, Mongolia, Montenegro, Morocco, Mozambique, Namibia, Nauru, Nepal, the Nether Antilles, the Netherlands, New Zealand, Nicaragua, Niger, Nigeria, Norway, Oman, Pakistan, Palau, Panama, Papua New Guinea, Paraguay, Peru, the Philippines, Poland, Portugal, the Republic of Moldova, Romania, Russia, Rwanda, Samoa, San Marino, Sao Tome and Principe, Saudi Arabia, Senegal, Serbia, the Seychelles, Sierra Leone, Singapore, Slovakia, Slovenia, the Solomon Islands, Somalia, South Africa, South Korea, Spain, Sri Lanka, St. Kitts and Nevis, St. Lucia, St. Vincent and the Grenadines, Suriname, Swaziland, Sweden, Switzerland, Taiwan, Tajikistan, Tanzania, Togo, Tonga, Trinidad and Tobago, Tunisia, Turkey, Turkmenistan, Tuvalu, Uganda, Ukraine, the United Arab Emirates, the United Kingdom, Uruguay, Uzbekistan, Vanuatu, Venezuela, Vietnam, Yemen, Zaire, Zambia, and Zimbabwe</li> </ul>	504593-004
<b>Intel Wi-Fi Link 5100 802.11a/b/g WLAN module</b> for use in all countries and regions	482957-001
<b>Intel Wi-Fi Link 5100 802.11a/b/g/n WLAN module</b> for use in all countries and regions	480985-001
<i>Broadcom 4322 AGN 802.11a/b/g WLAN modules:</i>	
<ul style="list-style-type: none"> <li><i>For use in Antigua and Barbuda, Barbados, Belize, Canada, the Cayman Islands, Guam, Puerto Rico, Trinidad and Tobago, the U.S. Virgin Islands, and the United States</i></li> </ul>	518434-001
<ul style="list-style-type: none"> <li><i>For use in Afghanistan, Albania, Algeria, Andorra, Angola, Antigua and Barbuda, Argentina, Armenia, Aruba, Australia, Austria, Azerbaijan, the Bahamas, Bahrain, Bangladesh, Barbados, Belarus, Belgium, Belize, Benin, Bermuda, Bhutan, Bolivia, Bosnia and Herzegovina, Botswana, Brazil, the British Virgin Islands, Brunei, Bulgaria, Burkina Faso, Burundi, Cameroon, Cape Verde, the Central African Republic, Chad, Chile, the People's Republic of China, Colombia, Comoros, the Congo, Costa Rica, Croatia, Cyprus, the Czech Republic, Denmark, Djibouti, Dominica, the Dominican Republic, East Timor, Ecuador, Egypt, El Salvador, Equatorial Guinea, Eritrea, Estonia, Ethiopia, Fiji, Finland, France, French Guiana, Gabon, Gambia, Georgia, Germany, Ghana, Gibraltar, Greece, Grenada, Guadeloupe, Guatemala, Guinea, Guinea-Bissau, Guyana, Haiti, Honduras, Hong Kong, Hungary, Iceland, India, Ireland, Israel, Italy, the Ivory Coast, Jamaica, Jordan, Kazakhstan, Kenya, Kiribati, Kyrgyzstan, Laos, Latvia, Lebanon, Lesotho, Liberia, Liechtenstein, Lithuania, Luxembourg, Macedonia, Madagascar, Malawi, Malaysia, the Maldives, Mali, Malta, the Marshall Islands, Martinique, Mauritania, Mauritius, Mexico, Micronesia, Monaco, Mongolia, Montenegro, Morocco, Mozambique, Namibia, Nauru, Nepal, the Nether Antilles, the Netherlands, New Zealand, Nicaragua, Niger, Nigeria, Norway, Oman, Pakistan, Palau, Panama, Papua New Guinea, Paraguay, Peru, the Philippines, Poland, Portugal, the Republic of Moldova, Romania, Russia, Rwanda, Samoa, San Marino, Sao Tome and Principe, Saudi Arabia, Senegal, Serbia, the Seychelles, Sierra Leone, Singapore, Slovakia, Slovenia, the Solomon Islands, Somalia, South Africa, South Korea, Spain, Sri Lanka, St. Kitts and Nevis, St. Lucia, St. Vincent and the Grenadines, Suriname, Swaziland, Sweden, Switzerland, Taiwan, Tajikistan, Tanzania, Togo, Tonga, Trinidad and Tobago, Tunisia, Turkey, Turkmenistan, Tuvalu, Uganda, Ukraine, the United Arab Emirates, the United Kingdom, Uruguay, Uzbekistan, Vanuatu, Venezuela, Vietnam, Yemen, Zaire, Zambia, and Zimbabwe</i></li> </ul>	518434-002
<i>Intel Wi-Fi Link 1000, 802.11b/g/n WLAN module:</i>	

Description	Spare part number
<ul style="list-style-type: none"> <li>For use in Andorra, Antigua and Barbuda, Argentina, Aruba, Australia, Austria, Azerbaijan, the Bahamas, Barbados, Belgium, Bolivia, Bosnia and Herzegovina, Brazil, Brunei, Bulgaria, Canada, Cayman Islands, Chile, China, Colombia, Costa Rica, Croatia, Cyprus, the Czech Republic, Denmark, the Dominican Republic, Ecuador, Egypt, El Salvador, Estonia, Finland, France, French Guiana, Guadeloupe, Guam, Georgia, Germany, Ghana, Greece, Guatemala, Haiti, Honduras, Hong Kong, Hungary, Iceland, India, Indonesia, Ireland, Israel, Italy, Ivory Coast, Jamaica, Japan, Jordan, Kenya, Kuwait, Kyrgyzstan, Latvia, Lebanon, Liechtenstein, Lithuania, Luxembourg, Malawi, Malaysia, Malta, Martinique, Mauritius, Mexico, Monaco, Montenegro, Morocco, the Nether Antilles, the Netherlands, New Zealand, Nicaragua, Nigeria, Oman, Pakistan, Panama, Paraguay, Peru, the Philippines, Poland, Portugal, Puerto Rico, Qatar, Romania, San Marino, Saudi Arabia, Senegal, Singapore, Slovakia, Slovenia, South Africa, South Korea, Spain, Sri Lanka, Sweden, Switzerland, Taiwan, Tanzania, Thailand, Trinidad and Tobago, Turkey, United Arab Emirates, the United Kingdom, the United States, Uruguay, the U.S. Virgin Islands, Venezuela, and Vietnam</li> </ul>	572520-001
<i>Intel Wi-Fi Link 1000, 802.11b/g WLAN module:</i>	
<ul style="list-style-type: none"> <li>For use in Russia and Ukraine</li> </ul>	585984-001

Before removing the WLAN module, follow these steps:

1. Shut down the computer. If you are unsure whether the computer is off or in Hibernation, turn the computer on, and then shut it down through the operating system.
2. Disconnect all external devices connected to the computer.
3. Disconnect the power from the computer by first unplugging the power cord from the AC outlet and then unplugging the AC adapter from the computer.
4. Remove the battery (see [Battery on page 41](#)).
5. Remove the switch cover and keyboard (see [Switch cover and keyboard on page 42](#)).
6. Remove the palm rest (see [Palm rest on page 50](#)).

Remove the WLAN module:

**CAUTION:** To prevent an unresponsive system, replace the wireless module only with a wireless module authorized for use in the computer by the governmental agency that regulates wireless devices in your country or region. If you replace the module and then receive a warning message, remove the module to restore computer functionality, and then contact technical support through Help and Support.

1. Position the computer with the front toward you.
2. Disconnect the WLAN antenna cables (1) from the terminals on the WLAN module.

**NOTE:** The black WLAN antenna cable is connected to the WLAN module “Main” terminal. The white WLAN antenna cable is connected to the WLAN module “Aux” terminal.

3. Remove the two Phillips PM2.5×3.0 screws (2) that secure the WLAN module to the computer. (The edge of the module opposite the slot rises away from the computer.)

4. Remove the WLAN module (3) by sliding the module away from the slot at an angle.

 **NOTE:** WLAN modules are designed with a notch (4) to prevent incorrect insertion into the WLAN module slot.

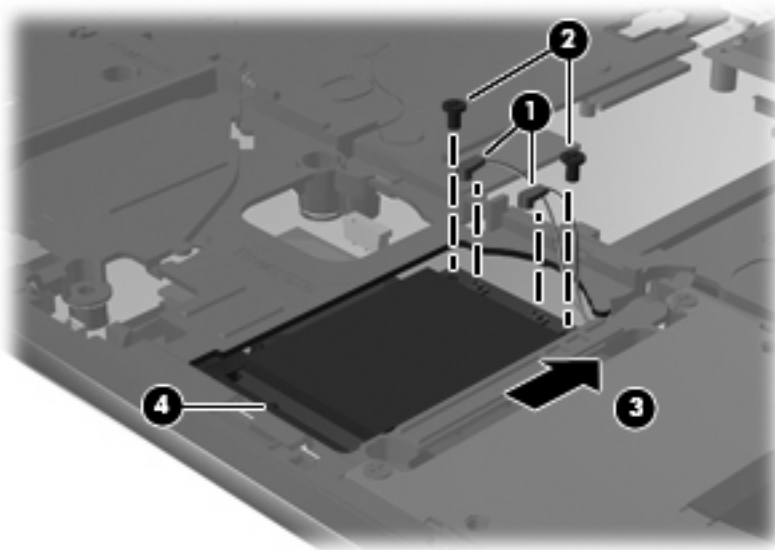

Reverse this procedure to install the WLAN module.

## Display assembly

 **NOTE:** All display assembly spare part kits include 2 WLAN antenna transceivers and cables.

Description	Spare part number
17.3-inch, HD+ BrightView display assembly with camera	535777-001
17.3-inch, HD+ BrightView display assembly	535779-001
17.3-inch, HD+ display assembly with camera	535778-001
17.3-inch, HD+ display assembly	535776-001

Before removing the display assembly, follow these steps:

1. Shut down the computer. If you are unsure whether the computer is off or in Hibernation, turn the computer on, and then shut it down through the operating system.
2. Disconnect all external devices connected to the computer.
3. Disconnect the power from the computer by first unplugging the power cord from the AC outlet and then unplugging the AC adapter from the computer.
4. Remove the battery (see [Battery on page 41](#)).
5. Remove the following components:
  - a. Switch cover (see [Switch cover and keyboard on page 42](#))
  - b. Keyboard (see [Switch cover and keyboard on page 42](#))
  - c. Speakers (see [Speakers on page 49](#))
  - d. Palm rest (see [Palm rest on page 50](#))

Remove the display cable:

1. Turn the computer right-side up, with the front toward you.
2. Open the computer as far as possible.
3. Disconnect the display panel cable **(1)** from the system board.
4. Disconnect the camera and microphone module cables **(2)** from the system board, and then remove the cables from the routing path **(3)**.

5. Remove the wireless antenna cables (4) from the clips and routing channels built into the top cover.

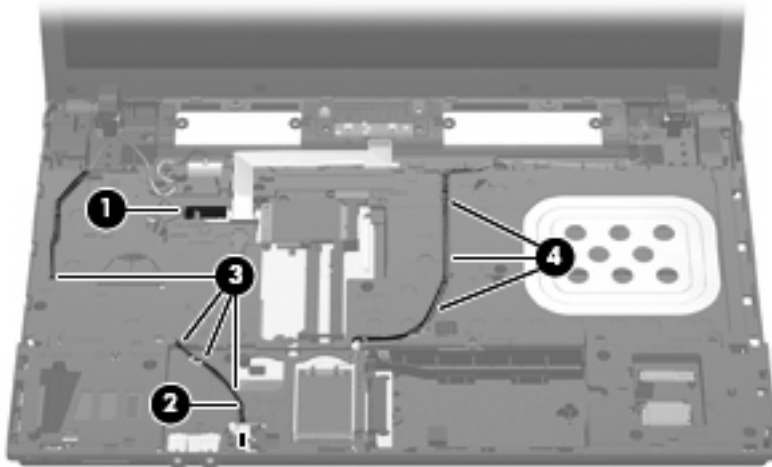

Remove the display assembly:

1. Remove the six Phillips PM2.5×4.5 screws (1) that secure the display assembly to the computer, and then lift the display assembly straight up (2) and remove it.

△ **CAUTION:** Support the display assembly when removing the following screws. Failure to support the display assembly can result in damage to the display assembly and other computer components.

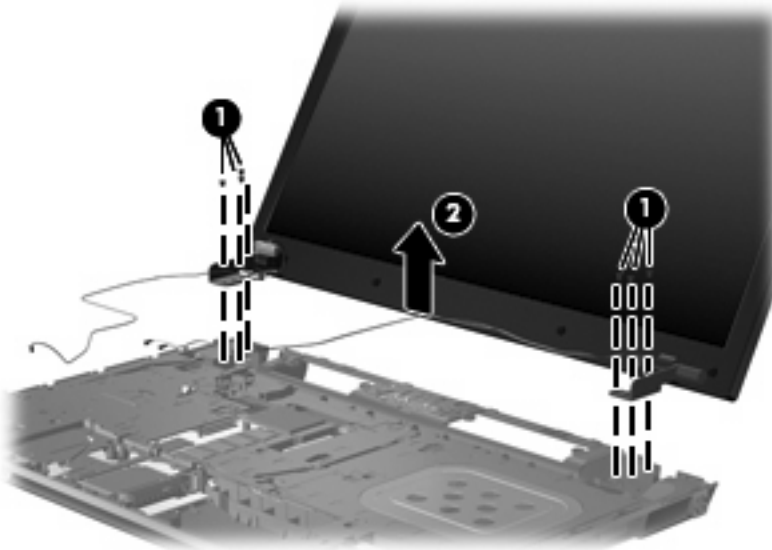

2. If it is necessary to replace the display bezel or display hinges, remove the eight rubber screw covers (1) and the eight Phillips PM2.5×4.5 screws (2) that secure the display bezel to the display assembly. The rubber screw covers are available in the Rubber Kit, spare part number 535793-001.

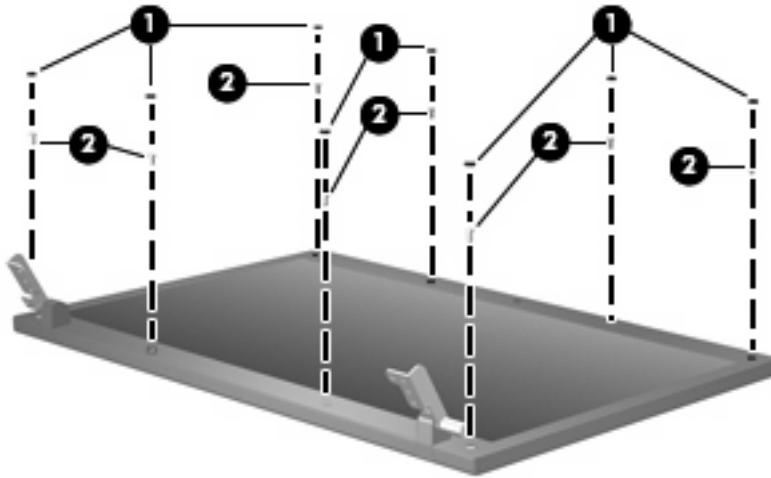

3. Lift the top inside edge of the display bezel (1) to detach it from the display assembly.
4. Lift the left and right inside edges of the of display bezel (2) to carefully detach them from the display assembly.
5. Carefully lift the bottom inside edge of the display bezel (3) to detach it from the display assembly.

 **NOTE:** Make note of the routing of the display cable and the wireless antenna cable.

6. Carefully remove the upper hinge cover clips from the lower hinge covers on the display assembly.

 **CAUTION:** The lower hinge covers can be damaged if care is not taken when removing the upper hinge cover clips.

7. Remove the display bezel from the display assembly (4). The display bezel is available using spare part numbers 535770-001 (for use only with models without a webcam) and 535769-001 (for use only with models with a webcam).

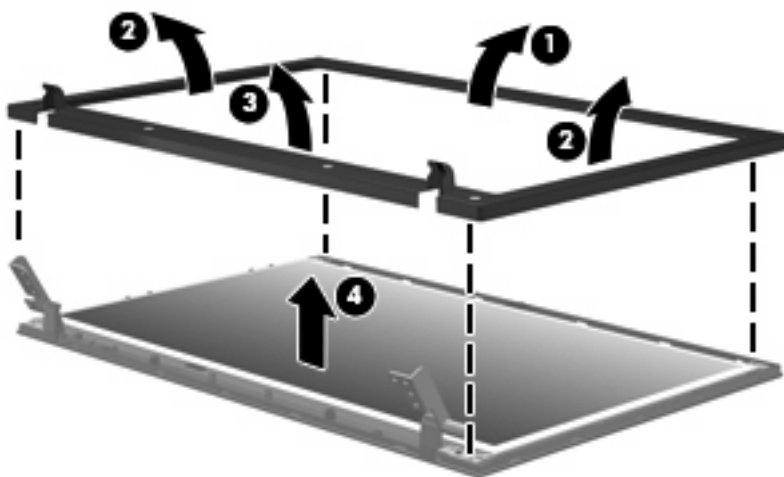

8. If it is necessary to replace the display hinges, remove the four Phillips PM2.5×5.0 screws (1) that secure the display panel to the display enclosure.
9. Remove the display panel (2).

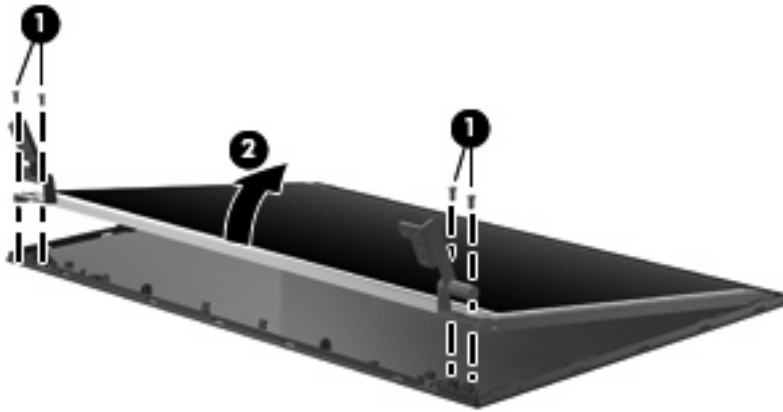

10. Remove the four Phillips PM2.0×3.0 screws (1) that secure each display hinge to the display panel.

 **NOTE:** When removing or replacing the eight Phillips screws, be sure to remove or replace them in the same sequence as the numbering found on the display hinges (1, 2, 3, 4).

11. Remove the display hinges (2). The left and right display hinges are available in the Bracket Kit, spare part number 535772-001.

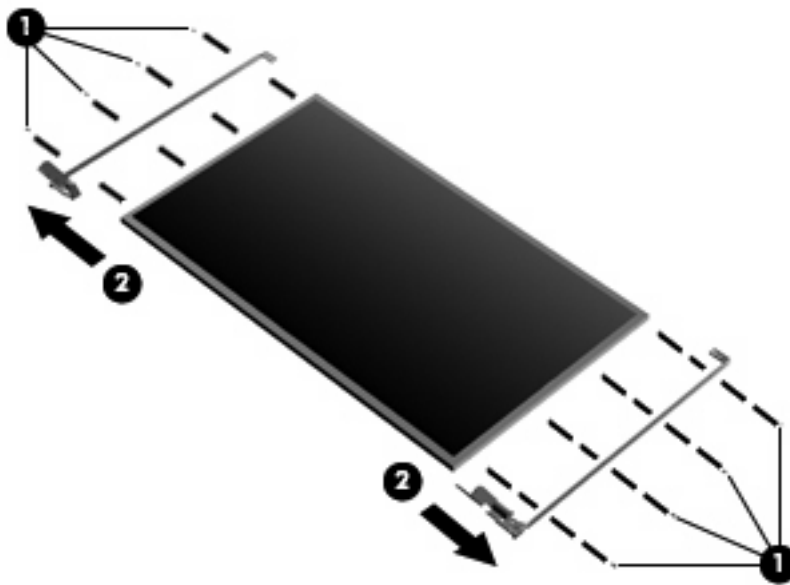

12. If it is necessary to replace the wireless antenna cables, lift the tape (1) that secures the cables to the display enclosure. The wireless antenna cables are included in the Display Cable Kit, spare part number 535771-001.
13. Remove the wireless antennas (2).



14. Remove the wireless antenna cables (3) from the clips and routing channels built into the top cover.

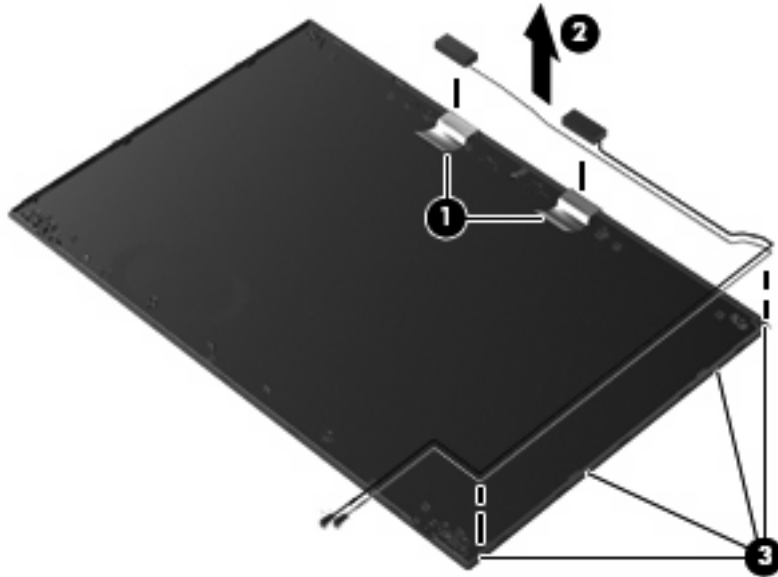

15. If it is necessary to replace the webcam, gently pull the webcam cables (1) from the clips and routing channels (2) built into the top cover. Lift the webcam (3) to remove it. The webcam cable is included in the Display Cable Kit, spare part number 535771-001.

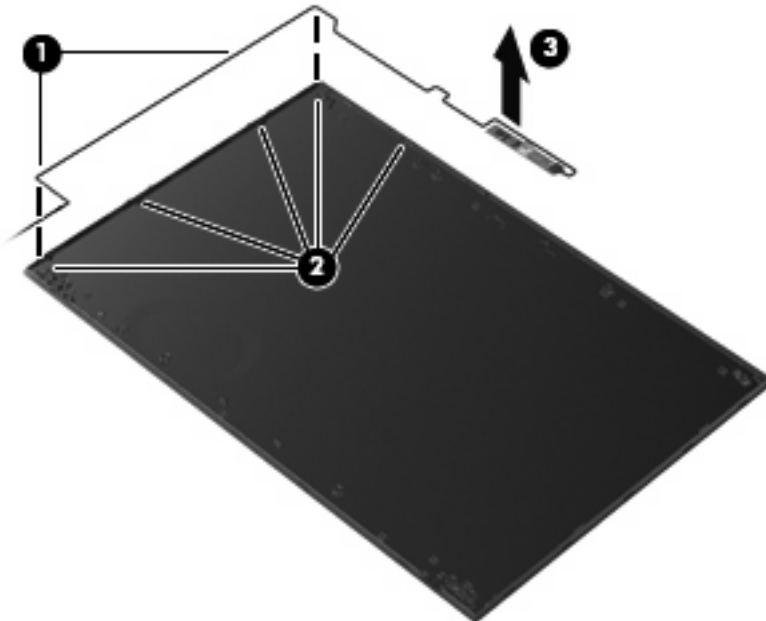

16. If it is necessary to replace the microphone, lift the microphone from the clip **(1)** and gently pull the microphone cable from the routing channels **(2)**. The microphone cable is included in the Display Cable Kit, spare part number 535771-001

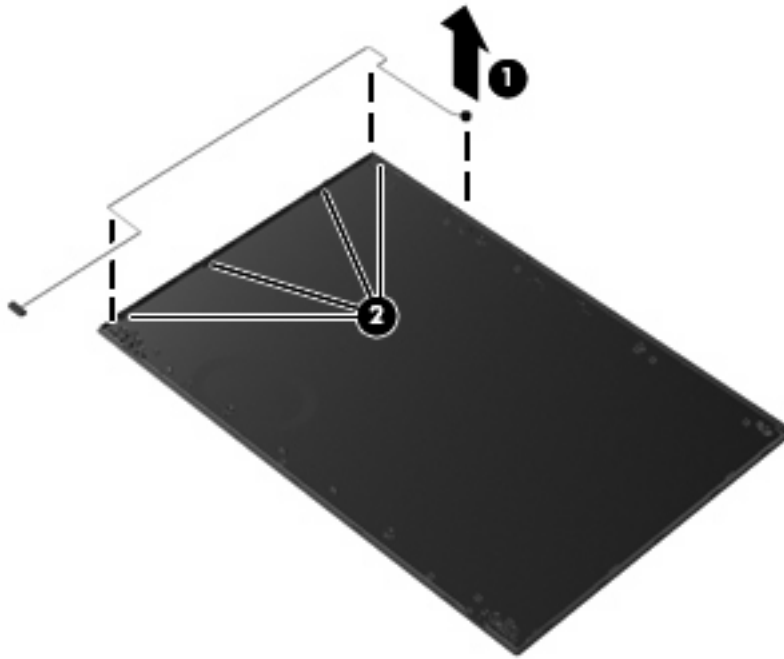

Reverse this procedure to reassemble and install the display assembly.

## Top cover

Description	Spare part number
<i>Top cover</i>	535796-001
<i>Power button board (includes cable)</i>	574493-001

Before removing the top cover, follow these steps:

1. Shut down the computer. If you are unsure whether the computer is off or in Hibernation, turn the computer on, and then shut it down through the operating system.
2. Disconnect all external devices connected to the computer.
3. Disconnect the power from the computer by first unplugging the power cord from the AC outlet and then unplugging the AC adapter from the computer.
4. Remove the battery (see [Battery on page 41](#)).
5. Remove the following components:
  - a. Switch cover and keyboard (see [Switch cover and keyboard on page 42](#))
  - b. Memory module (see [Memory module on page 45](#))
  - c. Optical drive (see [Optical drive on page 47](#))
  - d. Speakers (see [Speakers on page 49](#))
  - e. Palm rest (see [Palm rest on page 50](#))
  - f. WLAN module (see [WLAN module on page 55](#))
  - g. Hard drive (see [Hard drive on page 52](#))
  - h. Display assembly (see [Display assembly on page 59](#))

Remove the top cover:

1. Turn the computer right-side up, with the front toward you.

2. Release the ZIF connector (1) to which the power button cable is connected, and then disconnect the cable from the system board (2).

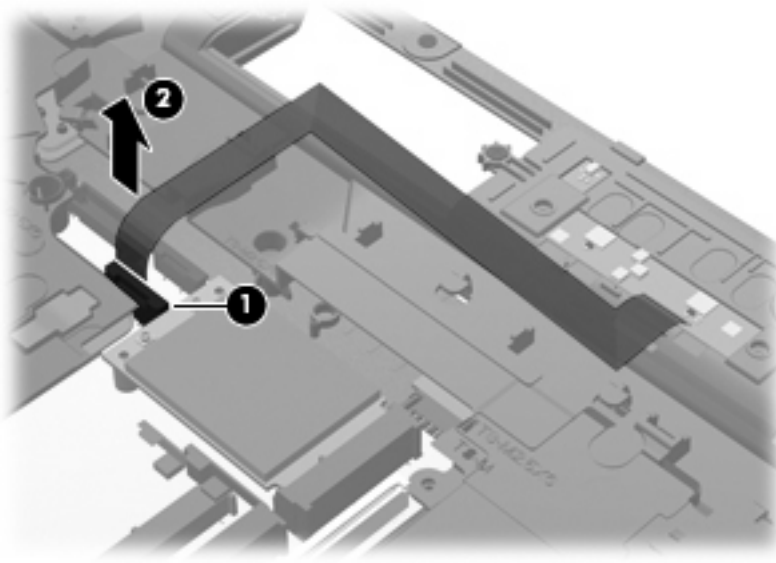

3. Remove the 22 top cover Torx T8M2.5×6.0 screws.

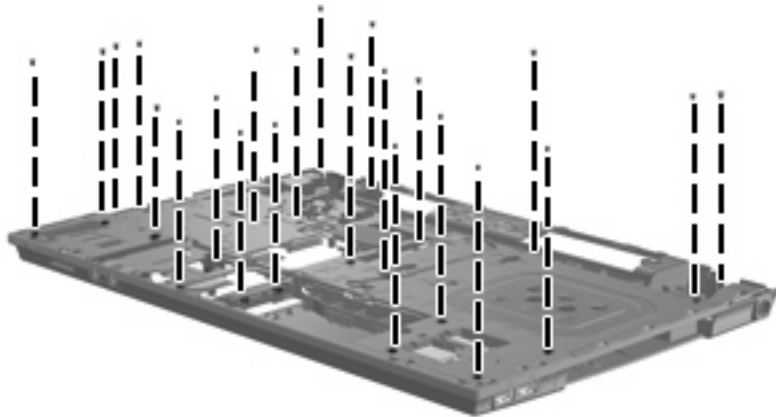

4. Lift the front edge of the top cover from beneath the audio jacks (1) until it disengages from the base enclosure. Then lift the top cover (2) from the base enclosure.



Reverse this procedure to install the top cover.

## Power button board

Description	Spare part number
Power button board (includes cable)	574493-001

Before removing the power button board, follow these steps:

1. Shut down the computer. If you are unsure whether the computer is off or in Hibernation, turn the computer on, and then shut it down through the operating system.
2. Disconnect all external devices connected to the computer.
3. Disconnect the power from the computer by first unplugging the power cord from the AC outlet and then unplugging the AC adapter from the computer.
4. Remove the battery (see [Battery on page 41](#)).
5. Remove the following components:
  - a. Switch cover and keyboard (see [Switch cover and keyboard on page 42](#))
  - b. Optical drive (see [Optical drive on page 47](#))
  - c. Speakers (see [Speakers on page 49](#))
  - d. Palm rest (see [Palm rest on page 50](#))
  - e. Hard drive (see [Hard drive on page 52](#))
  - f. Display assembly (see [Display assembly on page 59](#)).
  - g. Top cover (see [Top cover on page 65](#))

Remove the power button board:

1. Position the top cover upside-down with the rear toward you.
2. Lift the power button board straight up and off the top cover.

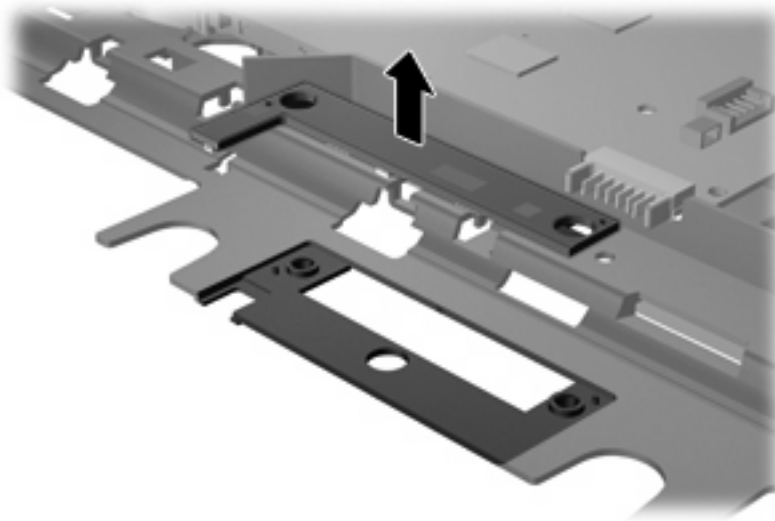

Reverse this procedure to install the power button board.

## Modem module

Description	Spare part number
For use in all countries and regions except Australia and New Zealand	510100-001
For use only in Australia and New Zealand	510100-011

Before removing the modem module, follow these steps:

1. Shut down the computer. If you are unsure whether the computer is off or in Hibernation, turn the computer on, and then shut it down through the operating system.
2. Disconnect all external devices connected to the computer.
3. Disconnect the power from the computer by first unplugging the power cord from the AC outlet and then unplugging the AC adapter from the computer.
4. Remove the battery (see [Battery on page 41](#)).
5. Remove the following components:
  - a. Switch cover and keyboard (see [Switch cover and keyboard on page 42](#))
  - b. Memory module (see [Memory module on page 45](#))
  - c. Optical drive (see [Optical drive on page 47](#))
  - d. Speakers (see [Speakers on page 49](#))
  - e. Palm rest (see [Palm rest on page 50](#))
  - f. WLAN module (see [WLAN module on page 55](#))
  - g. Hard drive (see [Hard drive on page 52](#))
  - h. Display assembly (see [Display assembly on page 59](#))
  - i. Top cover (see [Top cover on page 65](#))

Remove the modem module:

1. Remove the two Phillips PM2.5×3.0 screws **(1)** that secure the modem module to the system board.
2. Lift the rear edge of the modem module **(2)** to release it from the system board.

3. Lift the tape (3) to disconnect the modem module cable (4).

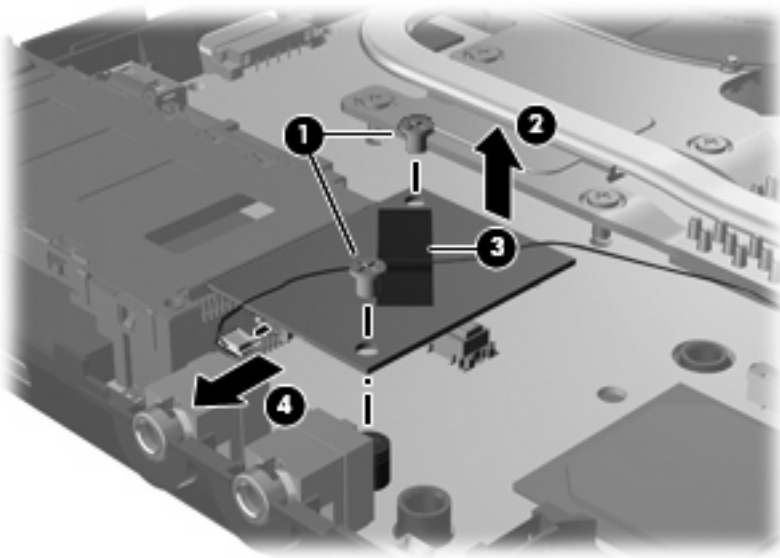

4. Remove the modem module.

Reverse this procedure to install the modem module.

## USB connector module

Description	Spare part number
Cable Kit	535757-001

Before removing the USB connector module, follow these steps:

1. Shut down the computer. If you are unsure whether the computer is off or in Hibernation, turn the computer on, and then shut it down through the operating system.
2. Disconnect all external devices connected to the computer.
3. Disconnect the power from the computer by first unplugging the power cord from the AC outlet and then unplugging the AC adapter from the computer.
4. Remove the battery (see [Battery on page 41](#)).
5. Remove the following components:
  - a. Switch cover and keyboard (see [Switch cover and keyboard on page 42](#))
  - b. Memory module (see [Memory module on page 45](#))
  - c. Optical drive (see [Optical drive on page 47](#))
  - d. Speakers (see [Speakers on page 49](#))
  - e. Palm rest (see [Palm rest on page 50](#))
  - f. WLAN module (see [WLAN module on page 55](#))
  - g. Hard drive (see [Hard drive on page 52](#))
  - h. Display assembly (see [Display assembly on page 59](#))
  - i. Top Cover (see [Top cover on page 65](#))

Remove the USB connector module:

1. Disconnect the USB cable from the system board **(1)**.
2. Lift up the USB cable from the routing channels in the base enclosure **(2)**.
3. Remove the short Phillips PM2.5×3.0 screw **(3)** and the long Phillips PM2.5×9.0 screw **(4)** that secure the USB connector module to the base enclosure.



4. Remove the USB connector module (5).

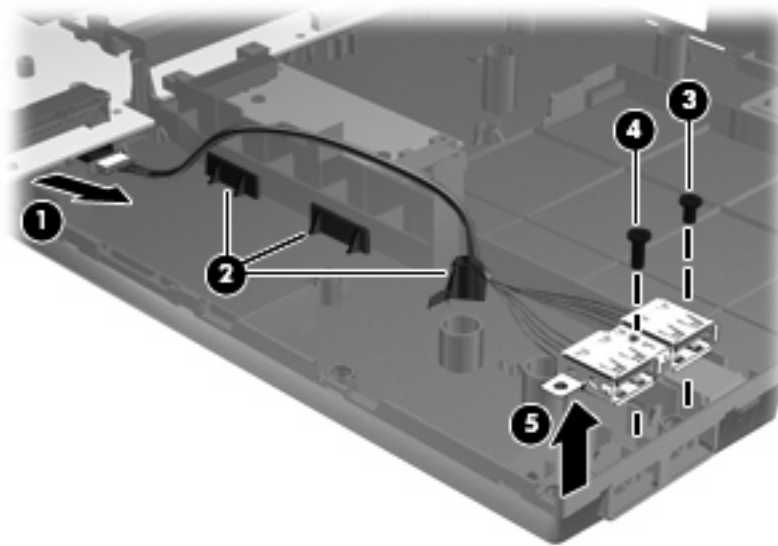

Reverse this procedure to install the USB connector module.

## RTC battery

Description	Spare part number
RTC battery	449137-001

Before removing the RTC battery, follow these steps:

1. Shut down the computer. If you are unsure whether the computer is off or in Hibernation, turn the computer on, and then shut it down through the operating system.
2. Disconnect all external devices connected to the computer.
3. Disconnect the power from the computer by first unplugging the power cord from the AC outlet and then unplugging the AC adapter from the computer.
4. Remove the battery (see [Battery on page 41](#)).
5. Remove the following components:
  - a. Switch cover and keyboard (see [Switch cover and keyboard on page 42](#))
  - b. Memory module (see [Memory module on page 45](#))
  - c. Optical drive (see [Optical drive on page 47](#))
  - d. Speakers (see [Speakers on page 49](#))
  - e. Palm rest (see [Palm rest on page 50](#))
  - f. WLAN module (see [WLAN module on page 55](#))
  - g. Hard drive (see [Hard drive on page 52](#))
  - h. Display assembly (see [Display assembly on page 59](#))
  - i. Top cover (see [Top cover on page 65](#))

Remove the RTC battery:

1. Position the base enclosure, with the front toward you.

2. Remove the RTC battery from the socket on the system board.

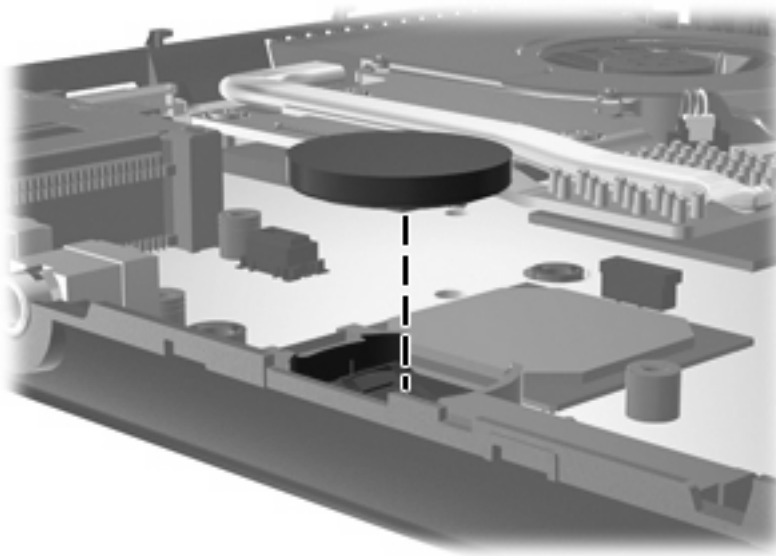

Reverse this procedure to install the RTC battery.

## Heat sink and fan

 **NOTE:** The heat sink spare part kit includes replacement thermal material.

Description	Spare part number
Heat sink	535767-001
Fan	535766-001001

Before removing the heat sink and fan, follow these steps:

1. Shut down the computer. If you are unsure whether the computer is off or in Hibernation, turn the computer on, and then shut it down through the operating system.
2. Disconnect all external devices connected to the computer.
3. Disconnect the power from the computer by first unplugging the power cord from the AC outlet and then unplugging the AC adapter from the computer.
4. Remove the battery (see [Battery on page 41](#)).
5. Remove the following components:
  - a. Switch cover and keyboard (see [Switch cover and keyboard on page 42](#))
  - b. Memory module (see [Memory module on page 45](#))
  - c. Optical drive (see [Optical drive on page 47](#))
  - d. Speakers (see [Speakers on page 49](#))
  - e. Palm rest (see [Palm rest on page 50](#))
  - f. WLAN module (see [WLAN module on page 55](#))
  - g. Hard drive (see [Hard drive on page 52](#))
  - h. Display assembly (see [Display assembly on page 59](#))
  - i. Top cover (see [Top cover on page 65](#))

Remove the heat sink and fan:

1. Following the 1 through 7 sequence stamped into the heat sink and fan, loosen the seven Phillips captive screws **(1)**.
2. Disconnect the fan cable **(2)** from the system board.

3. Lift the heat sink and fan from the system board (3).

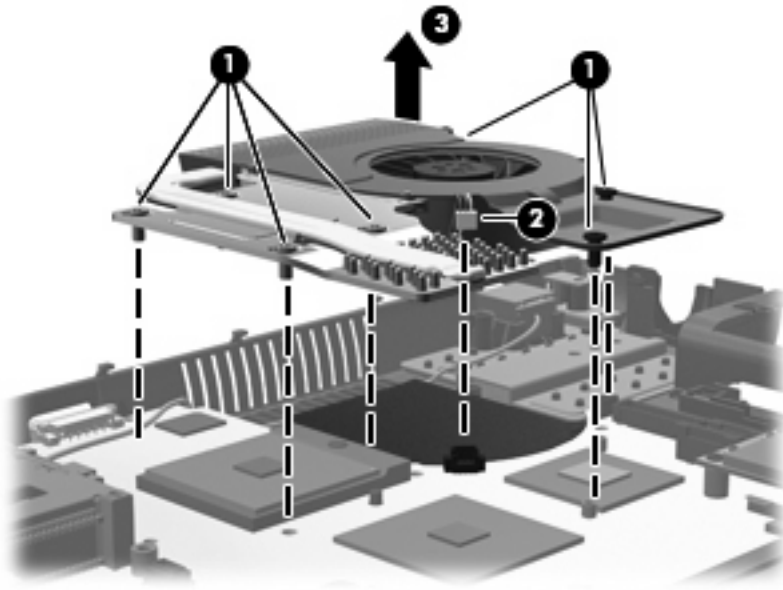

4. To remove the fan, turn the heat sink upside down and remove the three Phillips PM2.0×3.0 screws (1) that secure the fan to the heat sink.
5. Remove the fan (2).

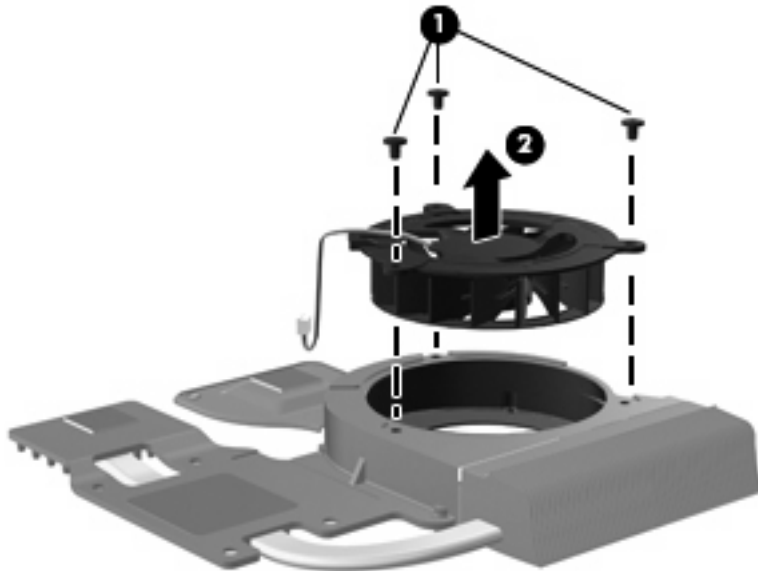

Reverse this procedure to install the fan.

 **NOTE:** To properly ventilate the computer, allow at least a 7.6-cm (3-inch) clearance on the left side of the computer.

The computer uses an electric fan for ventilation. The fan is controlled by a temperature sensor and is designed to turn on automatically when high temperature conditions exist. These conditions are affected by high external temperatures, system power consumption, power management/battery conservation configurations, battery fast charging, and software requirements. Exhaust air is displaced through the ventilation grill located on the left side of the computer.

 **NOTE:** The thermal material must be thoroughly cleaned from the surfaces of the system board (1), (2), and (3) and the heat sink components (4), (5), and (6) and must be replaced each time the heat sink is removed. Replacement thermal material is included with all heat sink, system board, cable, and processor spare part kits.

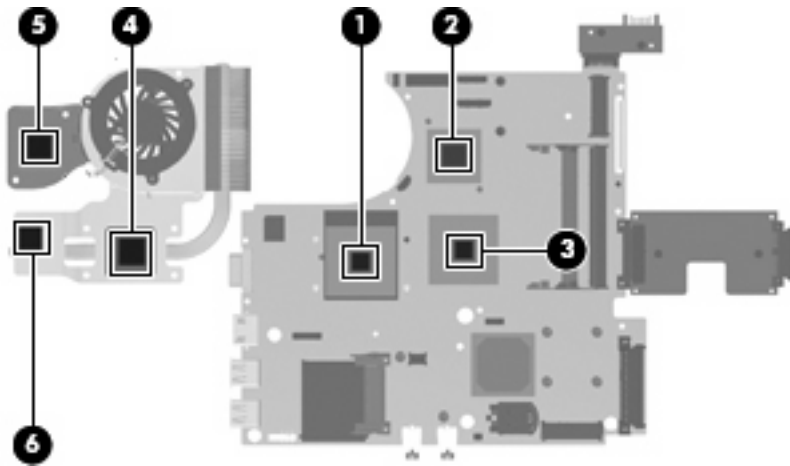

## RJ-45 (network) jack

 **NOTE:** The Cable Kit includes replacement thermal material.

Description	Spare part number
Cable Kit	535757-001

Before removing the RJ-45 (network) jack, follow these steps:

1. Shut down the computer. If you are unsure whether the computer is off or in Hibernation, turn the computer on, and then shut it down through the operating system.
2. Disconnect all external devices connected to the computer.
3. Disconnect the power from the computer by first unplugging the power cord from the AC outlet and then unplugging the AC adapter from the computer.
4. Remove the battery (see [Battery on page 41](#)).
5. Remove the following components:
  - a. Switch cover and keyboard (see [Switch cover and keyboard on page 42](#))
  - b. Memory module (see [Memory module on page 45](#))
  - c. Optical drive (see [Optical drive on page 47](#))
  - d. Speakers (see [Speakers on page 49](#))
  - e. Palm rest (see [Palm rest on page 50](#))
  - f. WLAN module (see [WLAN module on page 55](#))
  - g. Hard drive (see [Hard drive on page 52](#))

- h. Display assembly (see [Display assembly on page 59](#))
- i. Top Cover (see [Top cover on page 65](#))
- j. Heat sink and fan (see [Heat sink and fan on page 74](#))

Remove the RJ-45 (network) jack:

1. Disconnect the RJ-45 (network) cable from the system board (1) and remove the tape (2) that secures the cable to the base enclosure.
2. Lift the RJ-45 (network) jack (3) straight up from the retention clips to remove it.

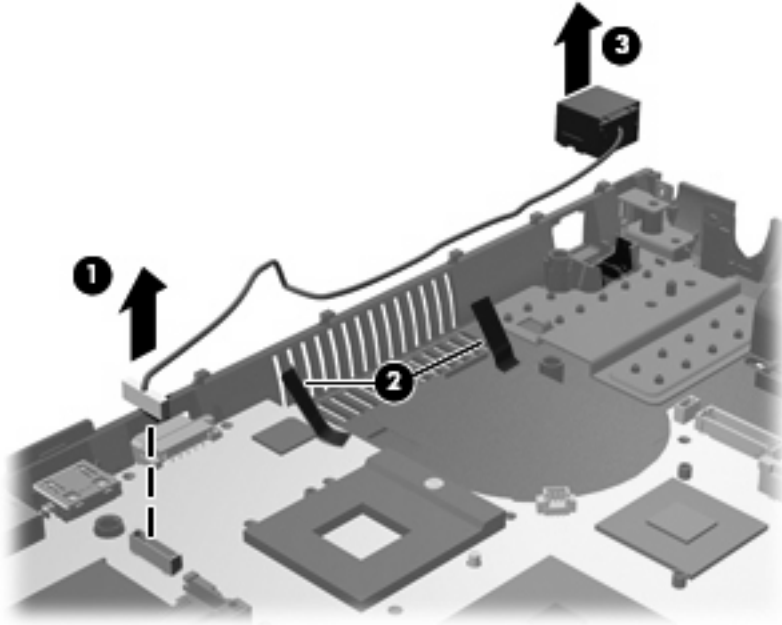

Reverse this procedure to install the RJ-45 (network) jack.

## Processor

 **NOTE:** All processor spare part kits include replacement thermal material.

Description	Spare part number
<b>Intel Core2 Duo processors:</b>	
T5870 (2.0 GHz, 667-MHz FSB, 2-MB L2 cache)	535835-001
T6570 (2.1 GHz, 800-MHz FSB, 2-MB L2 cache, TJ 100) (not available for Japan. Only available with Intel WLAN or no WLAN)	513598-001
<i>T6670 (2.2 GHz, 800-MHz FSB, 2-MB L2 cache)</i>	<i>572927-001</i>
P7370 (2.0 GHz, 1066-MHz FSB, 3-MB L2 cache) (Only available with Intel WLAN)	507966-001
<i>P7570 (2.26 GHz, 1066-MHz FSB, 3-MB L2 cache)</i>	<i>572930-001</i>
P8600 (2.4 GHz, 1066-MHz FSB, 3-MB L2 cache)	507961-001
P8700 (2.53 GHz, 1066-MHz FSB, 3-MB L2 cache)	507960-001
T9400 (2.53 GHz, 1066-MHz FSB, 6-MB L2 cache, 35W)	507954-001
T9600 (2.8 GHz, 1066-MHz FSB, 6-MB L2 cache)	507952-001
<b>Intel Pentium Dual-Core processors:</b>	
<i>T4200 (2.0 GHz, 800-MHz FSB, 1-MB L2 cache)</i>	<i>513599-001</i>
<i>T4300 (2.16 GHz, 800-MHz FSB, 1-MB L2 cache)</i>	<i>572929-001</i>
<b>Intel Celeron processors:</b>	
Intel Celeron 585 (2.16 GHz, 800-MHz FSB, 2-MB L2 cache)	519898-001
Intel Celeron 900 (2.20 GHz, 800-MHz FSB, 1-MB L2 cache)	534419-001
<b>Intel Celeron Dual-Core processors:</b>	
T1600 (1.66 GHz, 667-MHz FSB, 1-MB L2 cache)	532324-001
T1700 (1.83-GHz, 667-MHz FSB, 1-MB L2 cache)	534084-001
<i>T3000 (1.8-GHz, 800-MHz FSB, 1-MB L2 cache)</i>	<i>572926-001</i>
<i>T3100 (1.9-GHz, 800-MHz FSB, 1-MB L2 cache)</i>	<i>572925-001</i>

Before removing the processor, follow these steps:

1. Shut down the computer. If you are unsure whether the computer is off or in Hibernation, turn the computer on, and then shut it down through the operating system.
2. Disconnect all external devices connected to the computer.
3. Disconnect the power from the computer by first unplugging the power cord from the AC outlet and then unplugging the AC adapter from the computer.



4. Remove the battery (see [Battery on page 41](#)).
5. Remove the following components:
  - a. Switch cover and keyboard (see [Switch cover and keyboard on page 42](#))
  - b. Memory module (see [Memory module on page 45](#))
  - c. Optical drive (see [Optical drive on page 47](#))
  - d. Speakers (see [Speakers on page 49](#))
  - e. Palm rest (see [Palm rest on page 50](#))
  - f. Hard drive (see [Hard drive on page 52](#))
  - g. WLAN module (see [WLAN module on page 55](#))
  - h. Display assembly (see [Display assembly on page 59](#))
  - i. Top cover (see [Top cover on page 65](#))
  - j. Heat sink and fan (see [Heat sink and fan on page 74](#))

Remove the processor:

1. Position the base enclosure, with the front toward you.
2. Use a flat-bladed screwdriver to turn the processor locking screw **(1)** one-half turn counterclockwise until you hear a click.
3. Lift the processor **(2)** straight up and remove it.

---

 **NOTE:** When you install the processor, the gold triangle **(3)** on the processor must be aligned with the triangle **(4)** embossed on the processor socket.

---

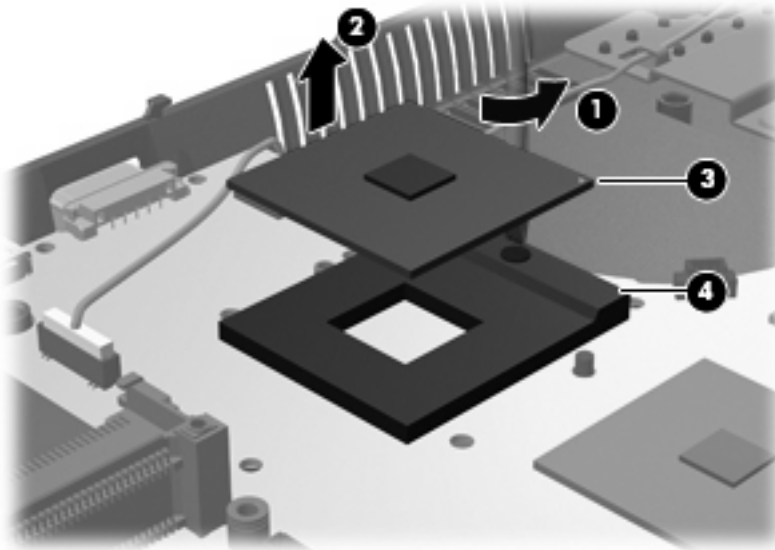

Reverse this procedure to install the processor.

## System board

 **NOTE:** All system board spare part kits include the ExpressCard assembly.

**NOTE:** All system board spare part kits include replacement thermal material.

Description	Spare part number
<i>System board for use in computers with DDR2 memory (includes replacement thermal material and the ExpressCard assembly)</i>	574508-001
<i>System board for use in computers with DDR3 memory (includes replacement thermal material and the ExpressCard assembly)</i>	583077-001

Before removing the system board, follow these steps:

1. Shut down the computer. If you are unsure whether the computer is off or in Hibernation, turn the computer on, and then shut it down through the operating system.
2. Disconnect all external devices connected to the computer.
3. Disconnect the power from the computer by first unplugging the power cord from the AC outlet and then unplugging the AC adapter from the computer.
4. Remove the battery (see [Battery on page 41](#)).
5. Remove the following components:
  - a. Switch cover and keyboard (see [Switch cover and keyboard on page 42](#))
  - b. Memory module (see [Memory module on page 45](#))
  - c. Optical drive (see [Optical drive on page 47](#))
  - d. Speakers (see [Speakers on page 49](#))
  - e. Palm rest (see [Palm rest on page 50](#))
  - f. Hard drive (see [Hard drive on page 52](#))
  - g. Display assembly (see [Display assembly on page 59](#))
  - h. Top cover (see [Top cover on page 65](#))

When replacing the system board, be sure that the following components are removed or disconnected from the defective system board and installed on the replacement system board:

- USB connector module cable (see [USB connector module on page 70](#))
- Bluetooth module cable (see [Bluetooth module on page 54](#))
- WLAN module cable (see [WLAN module on page 55](#))
- RTC battery (see [RTC battery on page 72](#))
- Heat sink and fan (see [Heat sink and fan on page 74](#))
- RJ-45 (network) cable (see [RJ-45 \(network\) jack on page 76](#))
- Processor (see [Processor on page 78](#))

Remove the system board:

1. Position the base enclosure, with the front toward you.
2. Lift the power connector (1) from the retention clips in the base enclosure and remove the power cable (2) from the routing clips.

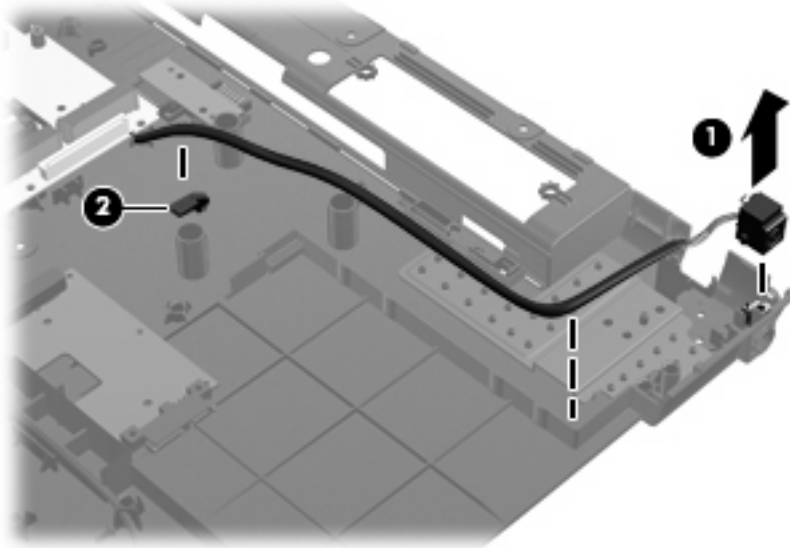

3. Remove the battery connector board (1).
4. Remove the two Phillips PM2.5×3.0 screws (2) that secure the optical drive connector board to the base enclosure.
5. Remove the Phillips PM2.5×3.0 screw (3) that secures the system board to the base enclosure.

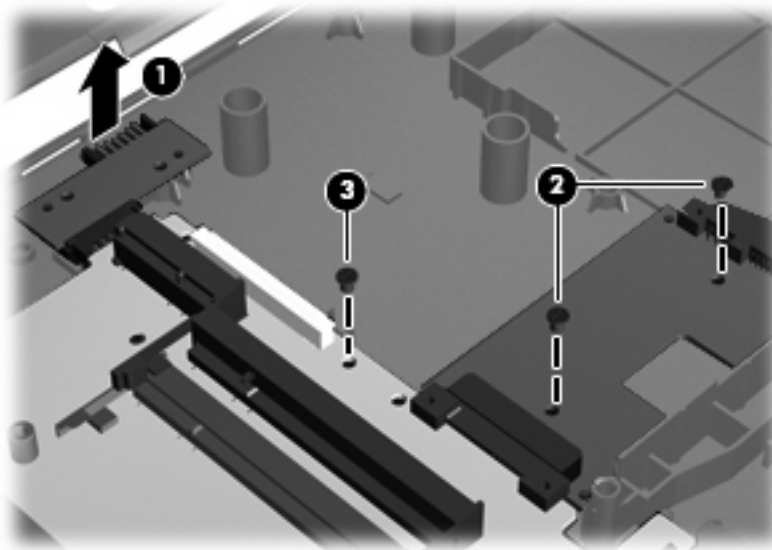

6. Lift the right side of the system board at an angle (1) and remove the optical drive board (2).

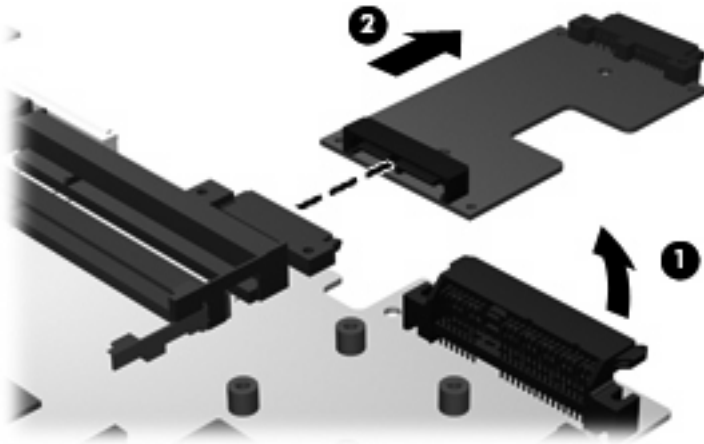

7. Flex the left side of the base enclosure (1) until the external monitor connector and the HDMI connector are clear of the openings in the base enclosure.
8. Lift the right side of the system board at an angle (2) and remove it (3) from the base enclosure.

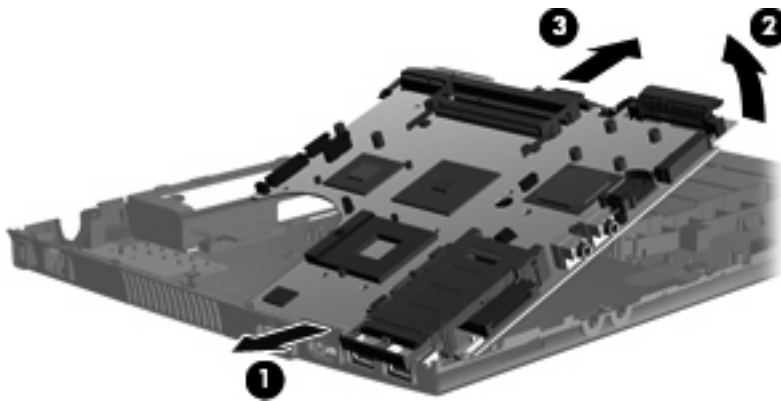

9. Turn the system board upside down with the rear panel toward you to disconnect the power cable.

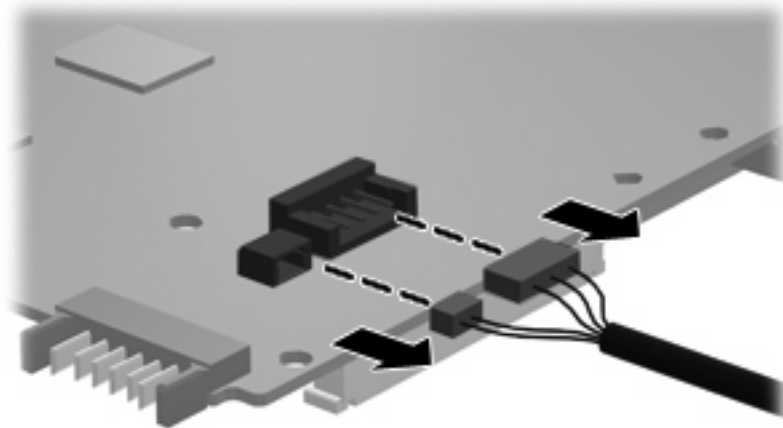

Reverse this procedure to install the system board.

---

# 5 Computer Setup

## Computer Setup in Windows Vista and Windows XP

### Starting Computer Setup

Computer Setup is a preinstalled, ROM-based utility that can be used even when the operating system is not working or will not load.

---

 **NOTE:** Some of the Computer Setup menu items listed in this guide may not be supported by your computer.

**NOTE:** An external keyboard or mouse connected to a USB port can be used with Computer Setup only if USB legacy support is enabled.

---

To start Computer Setup, follow these steps:

1. Turn on or restart the computer, and then press **esc** while the “Press the ESC key for Startup Menu” message is displayed at the bottom of the screen.
2. Press **f10** to enter BIOS Setup.

### Using Computer Setup

#### Navigating and selecting in Computer Setup

The information and settings in Computer Setup are accessed from the File, Security, Diagnostics, and System Configuration menus.

To navigate and select in Computer Setup, follow these steps:

1. Turn on or restart the computer, and then press **esc** while the “Press the ESC key for Startup Menu” message is displayed at the bottom of the screen.
  - To select a menu or a menu item, use the tab key and the keyboard arrow keys and then press **enter**, or use a pointing device to click the item.
  - To scroll up and down, click the up arrow or the down arrow in the upper-right corner of the screen, or use the up arrow key or the down arrow key.
  - To close open dialog boxes and return to the main Computer Setup screen, press **esc**, and then follow the on-screen instructions.

---

 **NOTE:** You can use either a pointing device (TouchPad, pointing stick, or USB mouse) or the keyboard to navigate and make selections in Computer Setup.

---

2. Press **f10** to enter BIOS Setup.
3. Select the **File, Security, Diagnostics,** or **System Configuration** menu.

To exit Computer Setup menus, choose one of the following methods:

- To exit Computer Setup menus without saving your changes, click the **Exit** icon in the lower-left corner of the screen, and then follow the on-screen instructions.

– or –

Use the tab key and the arrow keys to select **File > Ignore changes and exit**, and then press **enter**.

– or –

- To save your changes and exit Computer Setup menus, click the **Save** icon in the lower-left corner of the screen, and then follow the on-screen instructions.

– or –

Use the tab key and the arrow keys to select **File > Save changes and exit**, and then press **enter**.

Your changes go into effect when the computer restarts.

## Restoring factory settings in Computer Setup

---

 **NOTE:** Restoring defaults will not change the hard drive mode.

---

To return all settings in Computer Setup to the values that were set at the factory, follow these steps:

1. Turn on or restart the computer, and then press **esc** while the “Press the ESC key for Startup Menu” message is displayed at the bottom of the screen.
2. Press **f10** to enter BIOS Setup.
3. Use a pointing device or the arrow keys to select **File > Restore defaults**.
4. Follow the on-screen instructions.
5. To save your changes and exit, click the **Save** icon in the lower-left corner of the screen, and then follow the on-screen instructions.

– or –

Use the arrow keys to select **File > Save changes and exit**, and then press **enter**.

Your changes go into effect when the computer restarts.

---

 **NOTE:** Your password settings and security settings are not changed when you restore the factory settings.

---

## Computer Setup menus

The menu tables in this section provide an overview of Computer Setup options.

 **NOTE:** Some of the Computer Setup menu items listed in this chapter may not be supported by your computer.

## File Menu

Select	To do this
System Information	<ul style="list-style-type: none"><li>View identification information for the computer and the batteries in the system.</li><li>View specification information for the processor, cache and memory size, system ROM, video revision, and keyboard controller version.</li></ul>
Set System Date and Time	Set or change the date and time on the computer.
Restore defaults	Replace the configuration settings in Computer Setup with the original factory settings. (Hard drive mode, password settings, and security settings are not changed when you restore the factory settings.)
Ignore changes and exit	Cancel any changes entered during the current session. Then exit and restart the computer.
Save changes and exit	Save any changes entered during the current session. Then exit and restart the computer. Your changes go into effect when the computer restarts.

## Security menu

 **NOTE:** Some of the menu items listed in this section may not be supported by your computer.

Select	To do this
Setup BIOS Administrator Password	Set up a BIOS administrator password.
User Management (requires a BIOS administrator password)	<ul style="list-style-type: none"><li>Create a new BIOS user account.</li><li>View a list of ProtectTools users.</li></ul>
Password Policy (requires an administrator password)	Revise password policy criteria.
HP SpareKey	Enable/disable HP SpareKey (disabled by default).
Always Prompt for HP SpareKey Enrollment	Enable/disable HP SpareKey enrollment (disabled by default).
Allow Reset of HP ProtectTools security keys	Enable/disable reset of HP ProtectTools security keys.
Change Password	Enter, change, or delete a BIOS administrator password.
HP SpareKey Enrollment	Enroll or reset HP SpareKey, which is a set of security questions and answers used if you forget your password.
DriveLock Passwords	<ul style="list-style-type: none"><li>Enable/disable DriveLock on any computer hard drive (enabled by default).</li><li>Change a DriveLock user password or master password.</li></ul> <p><b>NOTE:</b> DriveLock settings are accessible only when you enter Computer Setup by turning on (not restarting) the computer.</p>
Automatic DriveLock	Enable/disable Automatic DriveLock support.

Select	To do this
Disk Sanitizer	Run Disk Sanitizer to destroy all existing data on the primary hard drive or the drive in the upgrade bay.  <b>CAUTION:</b> If you run Disk Sanitizer, the data on the selected drive is destroyed permanently.
System IDs	Enter a user-defined computer asset tracking number and ownership tag.

## Diagnostics menu

Select	To do this
System Diagnostics Menu	<ul style="list-style-type: none"> <li>• System Information—Displays the following information: <ul style="list-style-type: none"> <li>◦ Identification information for the computer and the batteries in the system.</li> <li>◦ Specification information for the processor, cache and memory size, system ROM, video revision, and keyboard controller version.</li> </ul> </li> <li>• Start-up Test—Verifies the system components needed for starting the computer.</li> <li>• Run-In Test—Runs a comprehensive check on system memory.</li> <li>• Hard Disk Test—Runs a comprehensive self-test on any hard drive in the system.</li> <li>• Error Log—Displays a log file if any errors have occurred.</li> </ul>

## System Configuration menu

 **NOTE:** Some of the listed System Configuration options may not be supported by your computer.

Select	To do this
Language	Change the Computer Setup language.



Select	To do this
Boot Options	<ul style="list-style-type: none"> <li>• Set a Startup Menu delay (in seconds).</li> <li>• Enable/disable Custom Logo (disabled by default).</li> <li>• Enable/disable Display Diagnostic URL (enabled by default).</li> <li>• Enable/disable CD-ROM boot (enabled by default).</li> <li>• Enable/disable SD Card boot (enabled by default).</li> <li>• Enable/disable floppy boot (enabled by default).</li> <li>• Enable/disable PXE Internal NIC boot (disabled by default).</li> <li>• Set the Express Boot Popup delay in seconds.</li> <li>• Set the boot order.</li> </ul>
Device Configurations	<ul style="list-style-type: none"> <li>• Enable/disable USB legacy support (enabled by default). When enabled, USB legacy support allows the following: <ul style="list-style-type: none"> <li>◦ Use of a USB keyboard in Computer Setup even when a Windows® operating system is not running.</li> <li>◦ Startup from bootable USB devices, including a hard drive, diskette drive, or optical drive connected by a USB port to the computer.</li> </ul> </li> <li>• Enable/disable fan always on while connected to an AC outlet (disabled by default).</li> <li>• Enable/disable Data Execution Prevention (select models only; disabled by default). When enabled, the processor can disable some virus code execution, which helps to improve computer security.</li> <li>• SATA (Serial Advanced Technology Attachment) device mode. The following options are available: <ul style="list-style-type: none"> <li>◦ AHCI (Advanced Host Controller Interface)</li> <li>◦ IDE (Integrated Drive Electronics)</li> </ul> <p><b>NOTE:</b> Availability of the options above varies by computer model.</p> </li> <li>• Enable/disable HP QuickLook 2 (enabled by default).</li> <li>• Enable/disable Virtualization Technology (select models only; disabled by default).</li> <li>• Enable/disable Dual Core CPU (enabled by default).</li> <li>• Enable/Disable Unified Extensible Firmware Interface (UEFI) mode (enabled by default).</li> </ul>

Select	To do this
Built-In Device Options	<ul style="list-style-type: none"> <li>• Enable/disable the wireless button state (enabled by default).</li> <li>• Enable/disable embedded WWAN device radio (enabled by default).</li> <li>• Enable/disable embedded Bluetooth device radio (enabled by default).</li> <li>• Enable/disable the Network Interface Controller (LAN) (enabled by default).</li> <li>• Set the wake on LAN state. Options include the following: <ul style="list-style-type: none"> <li>◦ Disabled</li> <li>◦ Boot to Network (set by default)</li> <li>◦ Follow Boot Order</li> </ul> </li> <li>• Enable/disable the optical disk drive (enabled by default).</li> <li>• Enable/disable the microphone.</li> <li>• Enable/disable a modem device (enabled by default).</li> <li>• Enable/disable the embedded WLAN device (enabled by default).</li> <li>• Enable/disable LAN/WLAN switching (disabled by default).</li> <li>• Enable/disable the integrated camera (select models only; enabled by default).</li> </ul>
Port Options (all are enabled by default)	<p><b>NOTE:</b> All port options are enabled by default.</p> <ul style="list-style-type: none"> <li>• Enable/disable the ExpressCard slot.</li> <li>• Enable/disable the flash media reader.</li> <li>• Enable/disable the USB port.</li> </ul> <p><b>CAUTION:</b> Disabling the USB port also disables MultiBay devices and ExpressCard devices on the advanced port replicator.</p>
Set Security Level	Change, view, or hide security levels for all BIOS menu items.
Restore Security Defaults	Restore the default security settings.

# Computer Setup in Linux

## Starting Computer Setup

Computer Setup is a preinstalled, ROM-based utility that can be used even when the operating system is not working or will not load.

 **NOTE:** Some of the Computer Setup menu items listed in this guide may not be supported by your computer.

**NOTE:** Pointing devices are not supported in Computer Setup. You must use the keyboard to navigate and make selections.

**NOTE:** An external keyboard connected by USB can be used with Computer Setup only if USB legacy support is enabled.

To start Computer Setup, follow these steps:

1. Turn on or restart the computer.
2. Before your operating system opens and while the “F10=ROM Based Setup” message is displayed in the lower-left corner of the screen, press **f10**.

## Using Computer Setup

### Navigating and selecting in Computer Setup

The information and settings in Computer Setup are accessed from the File, Security, Diagnostics, and System Configuration menus.

1. Open Computer Setup by turning on or restarting the computer, and then pressing **f10** while the “F10 = ROM Based Setup” message is displayed in the lower-left corner of the screen. Because Computer Setup is not operating system based, it does not support the TouchPad. Navigation and selection are by keystroke:
  - To choose a menu or a menu item, use the arrow keys.
  - To select an item, press **enter**.
  - To close open dialog boxes and return to the main Computer Setup screen, press **esc**.
  - To view navigation information, press **f1**.
  - To change the language, press **f2**.
2. Select the **File**, **Security**, **Diagnostics**, or **System Configuration** menu.
3. To exit Computer Setup, choose one of the following methods:
  - To exit Computer Setup without saving your preferences, use the arrow keys to select **File > Ignore Changes And Exit**. Then follow the instructions on the screen.
  - To save your preferences and exit Computer Setup, use the arrow keys to select **File > Save Changes And Exit**. Then follow the instructions on the screen.

Your preferences go into effect when the computer restarts.

## Restoring factory settings in Computer Setup

To return all settings in Computer Setup to the values that were set at the factory, follow these steps:

1. Open Computer Setup by turning on or restarting the computer, and then pressing **f10** while the "F10 = ROM Based Setup" message is displayed in the lower-left corner of the screen.
2. Use the arrow keys to select **File > Restore Defaults**, and then press **enter**.
3. When the confirmation dialog box opens, press **f10**.
4. To save your preferences and exit Computer Setup, use the arrow keys to select **File > Save Changes And Exit**. Then follow the instructions on the screen.

 **NOTE:** Your password settings and security settings are not changed when you restore the factory settings.

## Computer Setup menus

The menu tables in this section provide an overview of Computer Setup options.

 **NOTE:** Some of the Computer Setup menu items listed in this chapter may not be supported by your computer.

### File menu

Select	To do this
System information	<ul style="list-style-type: none"><li>• View identification information for the computer.</li><li>• View specification information for the processor, cache and memory size, and system ROM.</li></ul>
Restore Defaults	Replace the configuration settings in Computer Setup with the original factory settings. (Password settings and security settings are not changed when you restore the factory settings.)
Ignore Changes And Exit	Cancel any changes entered during the current session. Then exit and restart the computer.
Save Changes And Exit	Save any changes entered during the current session. Then exit and restart the computer. Your changes go into effect when the computer restarts.

### Security menu

Select	To do this
Setup Password	Enter, change, or delete a setup password.
Power-On Password	Enter, change, or delete a power-on password.
Password Options	<ul style="list-style-type: none"><li>• Enable/disable stringent security.</li><li>• Enable/disable stringent security.</li></ul>

DriveLock Passwords	<ul style="list-style-type: none"> <li>• Enable/disable DriveLock on any computer hard drive.</li> <li>• Enter, change, or disable DriveLock on an optional MultiBay hard drive.</li> </ul> <p><b>NOTE:</b> DriveLock settings are accessible only when you enter Computer Setup by turning on (not restarting) the computer.</p>
System IDs	Enter a user-defined computer asset tracking number and ownership tag.
Disk Sanitizer	<p>Run Disk Sanitizer to destroy all existing data on the primary hard drive. The following options are available:</p> <ul style="list-style-type: none"> <li>• Fast: Runs the Disk Sanitizer erase cycle once.</li> <li>• Fast: Runs the Disk Sanitizer erase cycle once.</li> <li>• Custom: Allows you to select the desired number of Disk Sanitizer erase cycles from a list.</li> </ul> <p><b>CAUTION:</b> If you run Disk Sanitizer, the data on the primary hard drive is destroyed permanently.</p>

## Diagnostics menu

Select	To do this
HDD Self-Test Option	Memory Check
Memory Check	Run a comprehensive check on system memory.

## System Configuration menu

 **NOTE:** Some of the listed System Configuration options may not be supported by your computer.

Select	To do this
Language	Change the Computer Setup language.

---

## Boot options

- Set an **f9**, **f10**, and **f12** delay when starting up.
- Enable/disable CD-ROM boot.
- Enable/disable floppy boot.
- Enable/disable internal network adapter boot.
- Enable/disable MultiBoot, which sets a boot order that can include most boot devices in the system.
- Set the Express Boot Popup delay in seconds.
- Set the boot order.
  - 1st boot device: USB CD-ROM
  - 2nd boot device: USB floppy
  - 3rd boot device: USB SuperDisk
  - 4th boot device: Notebook hard drive
  - 5th boot device: USB hard disk
  - 6th boot device: Network controller

---

## Device Configurations

- Swap the functions of the **fn** key and left **ctrl** key.
  - Enable/disable USB legacy support. When enabled, USB legacy support allows the following:
    - Use of a USB keyboard in Computer Setup even when a your operating system is not running.
    - Startup from bootable USB devices, including a hard drive, diskette drive, or optical drive connected by a USB port to the computer.
  - Enable/disable BIOS DMA data transfers.
  - Enable/disable fan always on while connected to an AC outlet.
  - Enable/disable data execution prevention.
  - Enable/disable LAN power saving mode.
  - Enable/disable SATA Native Mode.
  - Enable/disable Dual Core CPU.
  - Enable/disable HDD translation mode.
-

---

Built-in device options

- Enable/disable embedded WLAN Device Radio.
- Enable/disable embedded Bluetooth Device Radio.
- Enable/disable Network Interface Controller (NIC)
- Enable/disable LAN/WLAN Switching.
- Enable/disable Wake on LAN.
- Enable/disable the integrated camera (webcam)

---

Port options

- Enable/disable USB port.
  - Enable/disable ExpressCard slot.
-

# 6 Specifications

## Computer specifications

	Metric	U.S.
<b>Dimensions</b>		
Depth	27.0 cm	10.6 in
Width	41.06 cm	16.17 in
Height (front to rear)	3.20 to 3.68 cm	1.23 to 1.45 in
<b>Weight</b> (equipped with optical drive, hard drive, and battery)	3.08 kg	6.8 lbs
<b>Input power</b>		
Operating voltage	18.5 V dc @ 4.74 A-90 W	
Operating current	4.74 A	
<b>Temperature</b>		
Operating (not writing to optical disc)	0°C to 35°C	32°F to 95°F
Operating (writing to optical disc)	5°C to 35°C	41°F to 95°F
Nonoperating	-20°C to 60°C	-4°F to 140°F
<b>Relative humidity</b>		
Operating	10% to 90%	
Nonoperating	5% to 95%	
<b>Maximum altitude</b> (unpressurized)		
Operating	-15 m to 3,048 m	-50 ft to 10,000 ft
Nonoperating	-15 m to 12,192 m	-50 ft to 40,000 ft
<b>Shock</b>		
Operating	125 g, 2 ms, half-sine	
Nonoperating	200 g, 2 ms, half-sine	
<b>Random vibration</b>		
Operating	0.75 g zero-to-peak, 10 Hz to 500 Hz, 0.25 oct/min sweep rate	



	Metric	U.S.
Nonoperating	1.50 g zero-to-peak, 10 Hz to 500 Hz, 0.5 oct/min sweep rate	
<b>NOTE:</b> Applicable product safety standards specify thermal limits for plastic surfaces. The computer operates well within this range of temperatures.		

## 17.3-inch, HD+ display specifications

	Metric	U.S.
<b>Dimensions</b>		
Height	38.21 cm	15.0 in
Width	20.83 cm	8.2 in
Diagonal	43.94 cm	17.3 in
Active area	38.21 × 21.49 cm	15.04 × 8.46 in
Weight (maximum)	570 g	1.26 lbs
<b>Number of colors</b>	Up to 16.8 million	
<b>Contrast ratio</b>	500:1 (min)-BV, 300:1 (min)-AG	
<b>Brightness</b>	200 nits (typical)	
<b>Pixel resolution</b>		
LCD mode	TN	
Format	1600 × 900	
Active area	HD+	
<b>Backlight</b>	LED	
<b>Total power consumption</b>	5.3 W	
<b>Viewing angle</b>	SVA	

## Hard drive specifications

	500-GB	320-GB*	250-GB*	160-GB*
<b>Dimensions</b>				
Height	9.5 mm	9.5 mm	9.5 mm	9.5 mm
Width	70 mm	70 mm	70 mm	70 mm
Weight	101 g	101 g	101 g	101 g
<b>Interface type</b>	SATA	SATA	SATA	SATA
<b>Transfer rate</b>	100 MB/sec	100 MB/sec	100 MB/sec	100 MB/sec
<b>Security</b>	ATA security	ATA security	ATA security	ATA security
<b>Seek times</b> (typical read, including setting)				
Single track	3 ms	3 ms	3 ms	3 ms
Average	13 ms	13 ms	13 ms	13 ms
Maximum	24 ms	24 ms	24 ms	24 ms
<b>Logical blocks</b>	976,754,000	625,122,560	488,376,120	312,560,640
<b>Disc rotational speed</b>	5400 rpm	5400 rpm	5400 rpm	5400 rpm
<b>Operating temperature</b>	5°C to 55°C (41°F to 131°F)			
*1 GB = 1 billion bytes when referring to hard drive storage capacity. Actual accessible capacity is less. Actual drive specifications may differ slightly.				
<b>NOTE:</b> Certain restrictions and exclusions apply. Contact technical support for details.				

# DVD±RW and CD-RW SuperMulti Double-Layer Combo Drive with LightScribe specifications

<b>Applicable disc</b>	<b>Read:</b>	<b>Write:</b>
	CD-DA, CD+(E)G, CD-MIDI, CD-TEXT, CD-ROM, CD-ROM XA, MIXED MODE CD, CD-I, CD-I Bridge (Photo-CD, Video CD), Multisession CD (Photo-CD, CD-EXTRA, Portfolio, CD-R, CD-RW), CD-R, CD-RW, DVD-ROM (DVD-5, DVD-9, DVD-10, DVD-18), DVD-R, DVD-RW, DVD+R, DVD+RW. DVD-RAM	CD-R, CD-RW, DVD+R, DVD+RW, DVD-R, DVD-RW, DVD-RAM, LightScribe
<b>Access time</b>	<b>CD</b>	<b>DVD</b>
Random	< 150 ms	< 160 ms
<b>Cache buffer</b>	2 MB	
<b>Data transfer rate</b>		
24X CD-ROM	3,600 KB/sec	
8X DVD-ROM	10,800 KB/sec	
24X CD-R	3,600 KB/sec	
16X CD-RW	2,400 KB/sec	
8X DVD+R	10,800 KB/sec	
8x-DVD+RW	10.800 KB/sec	
8X DVD-R	10,800 KB/sec	
6X DVD-RW	8,100 KB/sec	
5X DVD-RAM	6,750 KB/sec	
4X-DVD+R Dual Layer	5,400 KB/sec	
4X-DVD-R Dual Layer	5,400 KB/sec	
<b>Transfer mode</b>	Multiword DMA Mode	

# Blu-ray ROM with LightScribe DVD±RW SuperMulti DL Drive specifications

Applicable disc	Read:	Write:	
	CD-DA, CD+(E)G, CD-MIDI, CD-TEXT, CD-ROM, CD-ROM XA, MIXED MODE CD, CD-I, CD-I Bridge (Photo-CD, Video CD), Multisession CD (Photo-CD, CD-EXTRA, Portfolio, CD-R, CD-RW), CD-R, CD-RW, DVD-ROM (DVD-5, DVD-9, DVD-10, DVD-18), DVD-R, DVD-RW, DVD+R, DVD+RW, DVD-RAM, BD-ROM, BD-R, BD-RE	CD-R, CD-RW, DVD+R, DVD+R(9), DVD+RW, DVD-R, DVD-R(9), DVD-RW, DVD-RAM, LightScribe	
Access time	CD	DVD	Blu-ray
Random	< 110 ms	< 130 ms	230 ms
Cache buffer	2 MB		
Data transfer rate			
24X CD-ROM	3,600 KB/sec		
8X DVD	10,800 KB/sec		
4X BD	1,800 KB/sec		
16X CD-R	1,200 KB/sec		
16X CD-RW	1,500 KB/sec		
8X DVD+R	10,800 KB/sec		
8X DVD+RW	10,800 KB/sec		
8X DVD-R	10,800 KB/sec		
8X DVD-RW	8,100 KB/sec		
4X DVD+R Dual Layer	5,400 KB/sec		
4X DVD-R Dual Layer	5,400 KB/sec		
5X DVD-RAM	6,750 KB/sec		
Transfer mode	Multiword DMA mode 2		

## DVD-ROM Drive

<b>Applicable disc</b>	CD-DA, CD+(E)G, CD-MIDI, CD-TEXT, CD-ROM, CD-ROM XA, MIXED MODE CD, CD-I, CD-I Bridge (Photo-CD, Video CD), Multisession CD (Photo-CD, CD-EXTRA, Portfolio, CD-R, CD-RW), CD-R, CD-RW, DVD-ROM (DVD-5, DVD-9, DVD-10, DVD-18), DVD-R, DVD-RW, DVD+R, DVD+RW, DVD-RAM	
<b>Access time</b>	<b>CD</b>	<b>DVD</b>
Random	< 110 ms	< 110 ms
<b>Cache buffer</b>	512 KB	
<b>Data transfer rate</b>		
CD-ROM (24X)	3600 KB/s (150 KB/s at 1X CD rate)	
DVD (8X)	10,800 KB/s (1,352 KB/s at 1X DVD rate)	
Multiword DMA mode 2	16.6 MB/s	

## System DMA specifications

<b>Hardware DMA</b>	<b>System function</b>
DMA0	Not applicable
DMA1*	Not applicable
DMA2*	Not applicable
DMA3	Not applicable
DMA4	Direct memory access controller
DMA5*	Available for ExpressCard
DMA6	Not assigned
DMA7	Not assigned

\*ExpressCard controller can use DMA 1, 2, or 5.

# System interrupt specifications

Hardware IRQ	System function
IRQ0	System timer
IRQ1	Standard 101-/102-Key or Microsoft Natural P/S2 Keyboard with HP QLB
IRQ2	Mobile Intel® 4 Series Chipset PCI Express Root Port-2A41
IRQ3	Intel® ICH9 Family PCI Express Root Port1-2940
IRQ4	Intel® ICH9 Family PCI Express Root Port2-2942
IRQ5	Intel® ICH9 Family PCI Express Root Port3-2944
IRQ6	Intel® ICH9 Family PCI Express Root Port5-2948
IRQ7	Intel® ICH9 Family PCI Express Root Port6-294A
IRQ8	ATI Mobility Radeon HD 4330
IRQ9	Intel® WiFi Link 5100 ABG
IRQ12	Synaptics PS/2 Port TouchPad
IRQ13	Numeric data processor
IRQ16	Intel® ICH9 Family USB Universal Host Controller-2937
IRQ-17	High Definition Audio Controller
IRQ-18	Intel® ICH9 Family USB Universal Host Controller-2939
IRQ-19	Intel® ICH9 Family USB Universal Host Controller-293C
IRQ-20	Intel® ICH9 Family USB Universal Host Controller-293A
IRQ-21	Intel® ICH9M-E/M SATA AHCI Controller
IRQ-22	Intel® ICH9 Family USB Universal Host Controller-2935

\*Default configuration; audio possible configurations are IRQ5, IRQ7, IRQ9, IRQ10, or none.

**NOTE:** ExpressCards may assert IRQ3, IRQ4, IRQ5, IRQ7, IRQ9, IRQ10, IRQ11, or IRQ15. Either the infrared or the serial port may assert IRQ3 or IRQ4.

## System I/O address specifications

I/O address (hex)	System function (shipping configuration)
000-01F	Direct memory access controller
000-CF7	PCI Bus
020-021	Programmable interrupt controller
024-025	Programmable interrupt controller
028-029	Programmable interrupt controller
02C-02D	Programmable interrupt controller
02E-02F	Motherboard resources
030-031	Programmable interrupt controller
034-035	Programmable interrupt controller
038-039	Programmable interrupt controller
03C-03D	Programmable interrupt controller
040-043	System timer
04E-04F	Motherboard resources
050-053	System timer
060-060	Standard 101-/102-Key or Microsoft Natural P/S2 Keyboard with HP QLB
061-061	Motherboard resources
062-062	Microsoft ACPI-Compliant Embedded Controller
063-063	Motherboard resources
064-064	Standard 101-/102-Key or Microsoft Natural P/S2 Keyboard with HP QLB
065-065	Motherboard resources
066-066	Microsoft ACPI-Compliant Embedded Controller
067-067	Motherboard resources
070-070	Motherboard resources
070-077	System CMOS/real time clock
080-080	Motherboard resources
081-091	Direct memory access controller
092-092	Motherboard resources
093-09F	Direct memory access controller
0A0-0A1	Programmable interrupt controller
0A4-0A5	Programmable interrupt controller
0A8-0A9	Programmable interrupt controller
0AC-0AD	Programmable interrupt controller
0B0-0B1	Programmable interrupt controller

<b>I/O address (hex)</b>	<b>System function (shipping configuration)</b>
0C0-0DF	Direct memory access controller
0F0-0F0	Numeric data processor
200-27F	Motherboard resources
3B0-3BB	ATI Mobility Radeon HD 4330
3B0-3BB	Mobile Intel® 4 Series Chipset PCI Express Root Port-2A41
3C0-3DF	ATI Mobility Radeon HD 4330
3C0-3DF	Mobile Intel® 4 Series Chipset PCI Express Root Port-2A41
400-47F	Motherboard resources
4D0-4D1	Programmable interrupt controller
500-57F	Motherboard resources
0D00-FFFF	PCI bus
1000-1003	Motherboard resources
1010-101F	Motherboard resources
2000-20FF	Marvell Yukon 88E88072 PCI-E Gigabit Ethernet Controller
2000-20FF	Intel® ICH9 Family PCI Express Root Port6-294A
3000-4FFF	Intel® ICH9 Family PCI Express Root Port5-2948
5000-6FFF	Intel® ICH9 Family PCI Express Root Port3-2944
7000-70FF	ATI Mobility Radeon HD 4330
7000-70FF	Mobile Intel® 4 Series Chipset PCI Express Root Port-2A41
8000-801F	Intel® ICH9M-E/M SATA AHCI Controller
8020-803F	Intel® ICH9 Family USB Universal Host Controller-2936
8040-805F	Intel® ICH9 Family USB Universal Host Controller-2935
8060-807F	Intel® ICH9 Family USB Universal Host Controller-2934
8080-809F	Intel® ICH9 Family USB Universal Host Controller-2939
80A0-80BF	Intel® ICH9 Family USB Universal Host Controller-2938
80C0-80DF	Intel® ICH9 Family USB Universal Host Controller-2937
CF8-CFB	
80E0-80E7	Intel® ICH9M-E/M SATA AHCI Controller
80E8-80EF	Intel® ICH9M-E/M SATA AHCI Controller
80F0-80F3	Intel® ICH9M-E/M SATA AHCI Controller
80F4-80F7	Intel® ICH9M-E/M SATA AHCI Controller
EF80-EF9F	Motherboard resources
FE00-FE0F	Motherboard resources



<b>I/O address (hex)</b>	<b>System function (shipping configuration)</b>
FE80-FE8F	Motherboard resources
FFFF—FFFF	Motherboard resources

## System memory map specifications

<b>Memory address</b>	<b>System function</b>
000A0000-000BFFFF	ATI Mobility Radeon HD 4330
000A0000-000BFFFF	Mobile Intel® 4 Series Chipset PCI Express Root Port-2A41
000A0000-000BFFFF	PCI bus
C0000000-CFFFFFFF	ATI Mobility Radeon HD 4330
C0000000-CFFFFFFF	Mobile Intel® 4 Series Chipset PCI Express Root Port-2A41
C0000000-DFFFFFFF	PCI bus
D0000000-D00FFFFF	Intel® 82801 PCI Bridge-2448
D0100000-D0103FFF	Marvell Yukon 88E88072 PCI-E Gigabit Ethernet Controller
D0100000-D01FFFFF	Intel® ICH9 Family PCI Express Root Port6-294A
D0200000-D41FFFFF	Intel® ICH9 Family PCI Express Root Port5-2948
D4200000-D81FFFFF	Intel® ICH9 Family PCI Express Root Port3-2944

## 7 Screw listing

This chapter provides specification and reference information for the screws and screw locks used in the computer. All screws listed in this section are available in the Screw Kit, spare part number 535794-001.

### Phillips PM2.0×3.0 screw

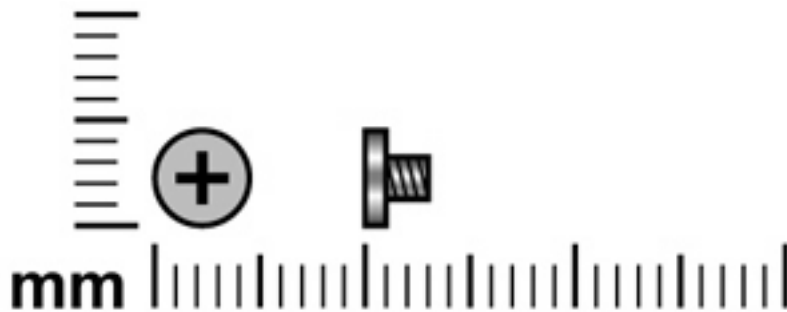

Color	Quantity	Length	Thread	Head diameter
Silver	21	3.0 mm	2.0 mm	5.0 mm



**Where used:** 2 screws that secure the optical drive bracket to the optical drive

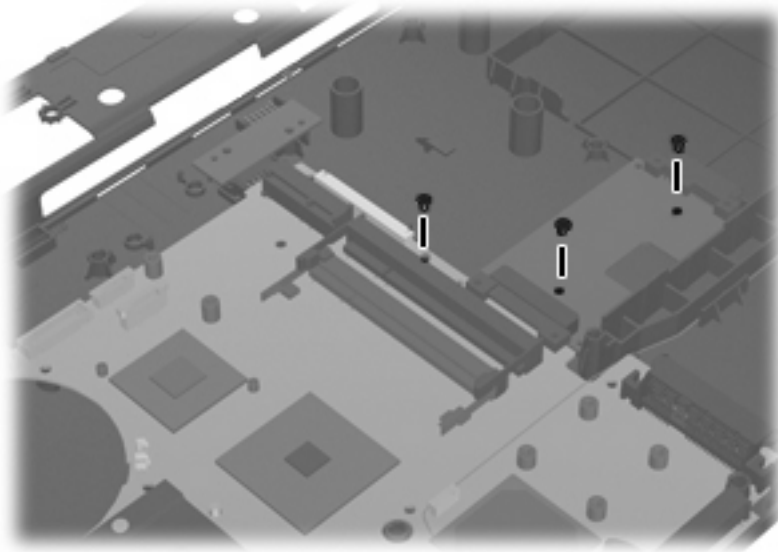
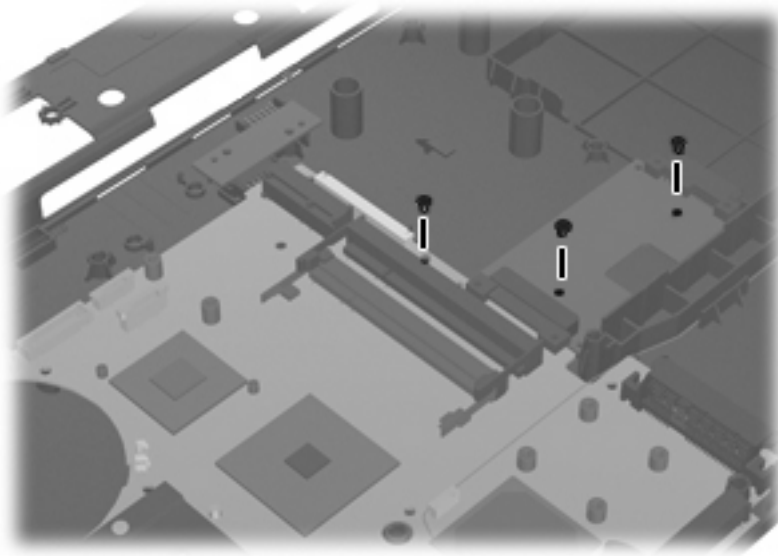

**Where used:** 3 screws that secure the system board to the base enclosure

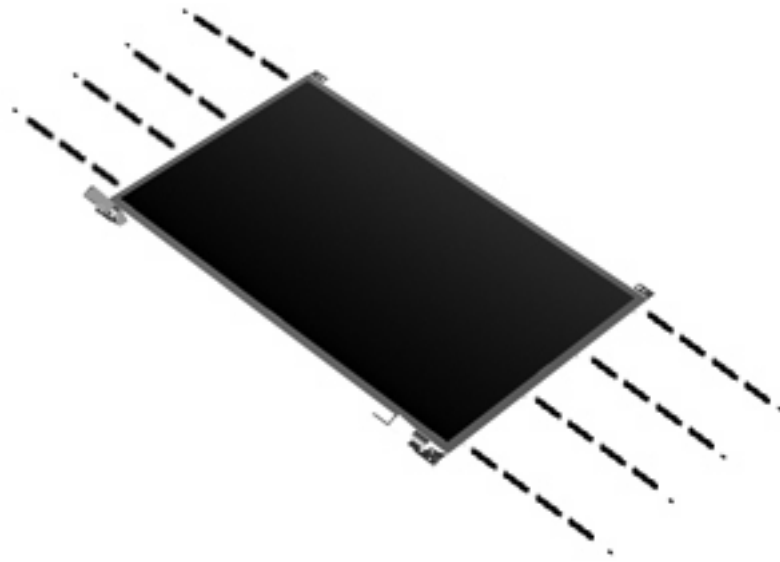

Where used: 8 screws that secure the display hinges to the display panel

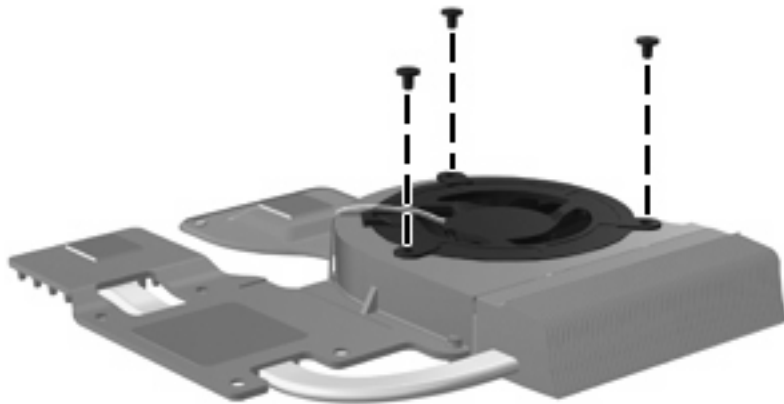

**Where used:** 3 screws that secure the fan to the heat sink

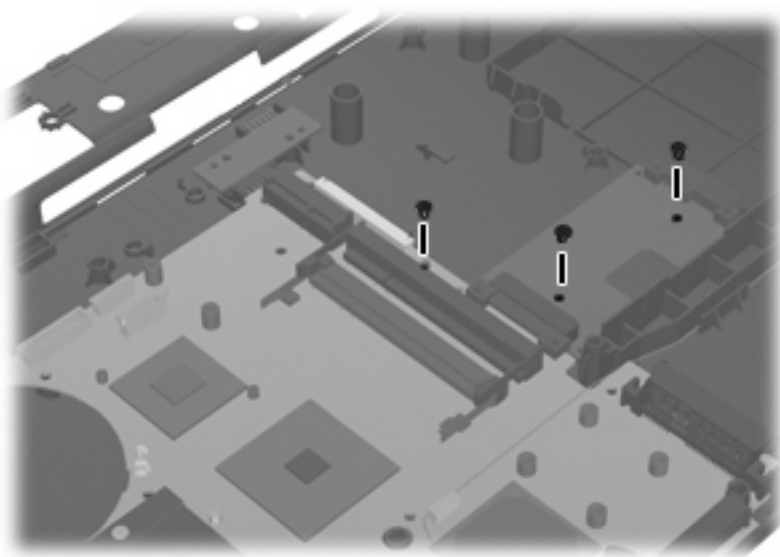

**Where used:** 3 screws that secure the system board to the base enclosure.

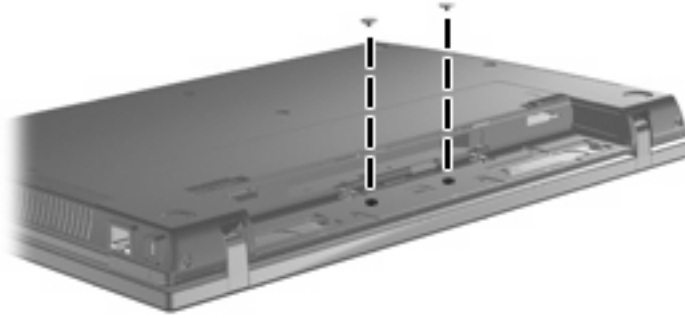

**Where used:** 2 screws that secure the top cover and battery connector board to the base enclosure

## Phillips PM2.5×4.5 screw

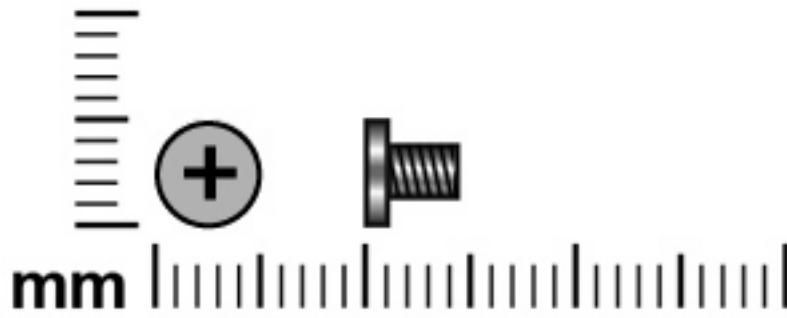

Color	Quantity	Length	Thread	Head diameter
Black	21	4.5 mm	2.5 mm	5.0 mm



**Where used:** 4 screws that secure the display panel to the display assembly



**Where used:** 2 screws that secure the keyboard to the computer

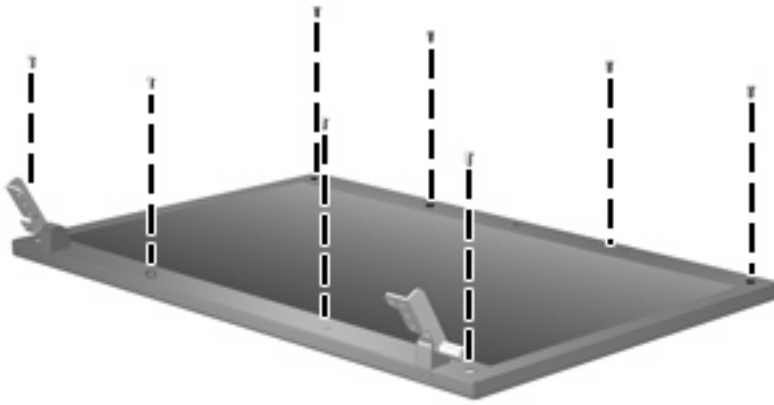

**Where used:** 8 screws that secure the display bezel to the display enclosure



**Where used:** 1 screw that secures the optical drive to the computer

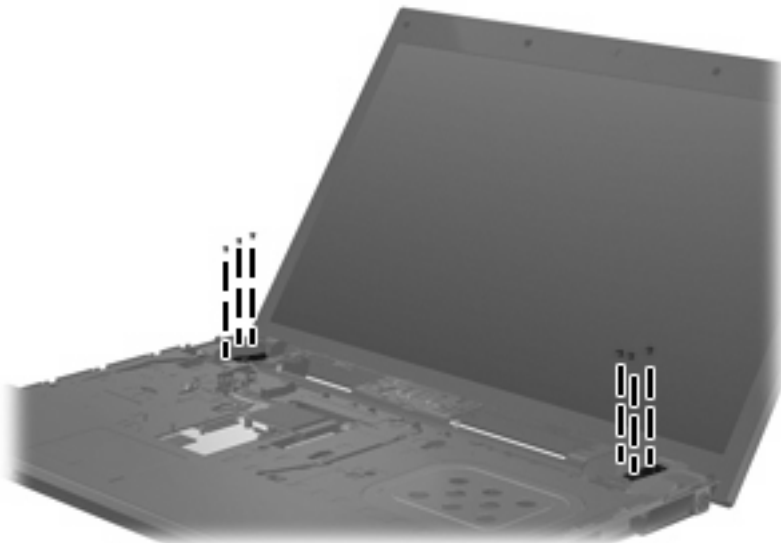

**Where used:** 6 screws that secure the display assembly to the computer.

## Phillips PM3.0×4.0 screw

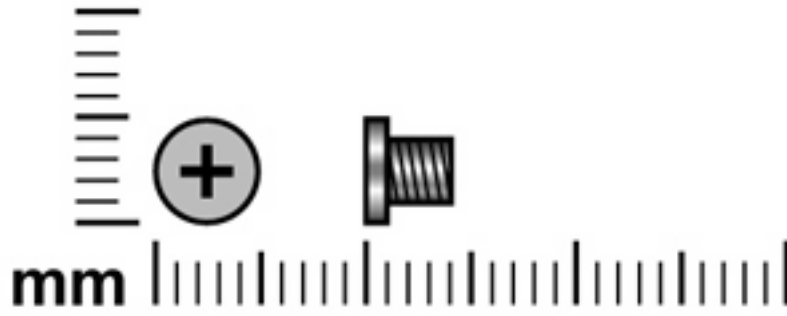

Color	Quantity	Length	Thread	Head diameter
Silver	4	4.0 mm	3.0 mm	5.0 mm



**Where used:** 4 screws that secure the hard drive bracket to the hard drive



## Phillips PM2.5×3.0 screw

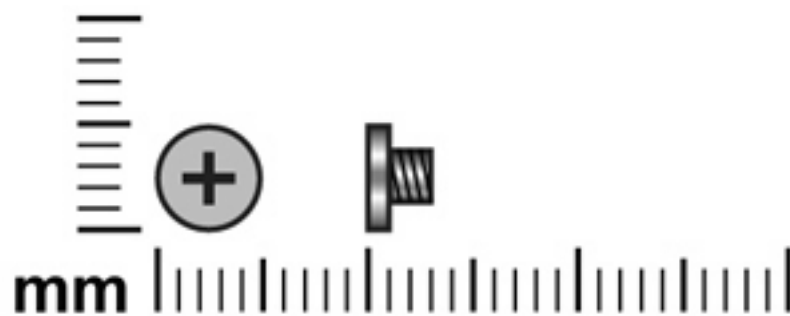

Color	Quantity	Length	Thread	Head diameter
Black	11	3.0 mm	2.5 mm	5.0 mm

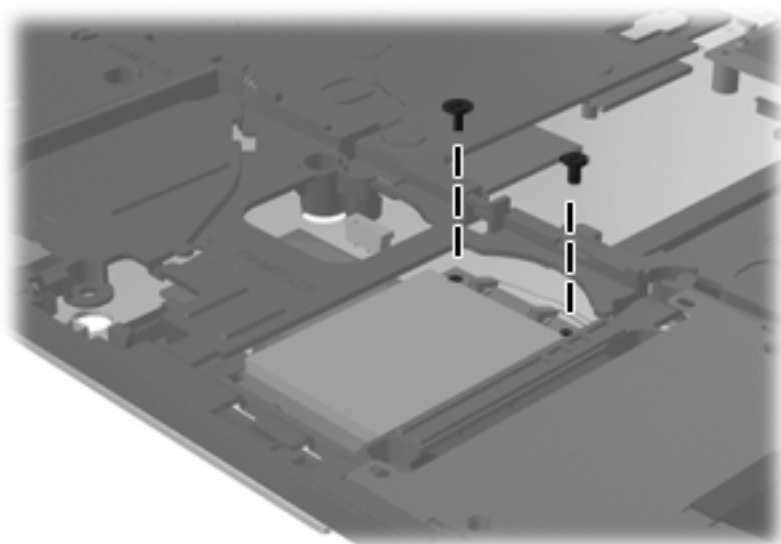

**Where used:** 2 screws that secure the WLAN module to the system board

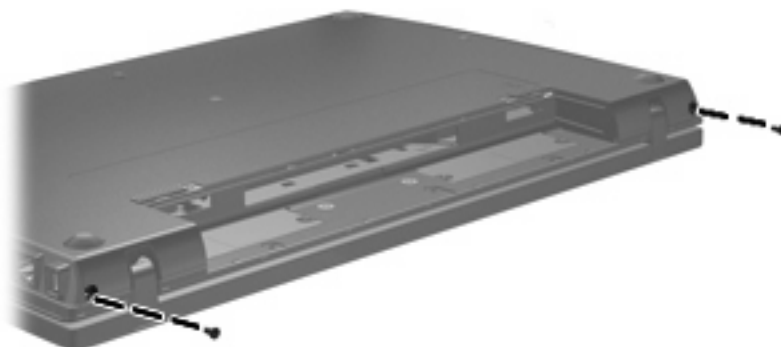

**Where used:** 2 screws that secure the switch cover to the computer

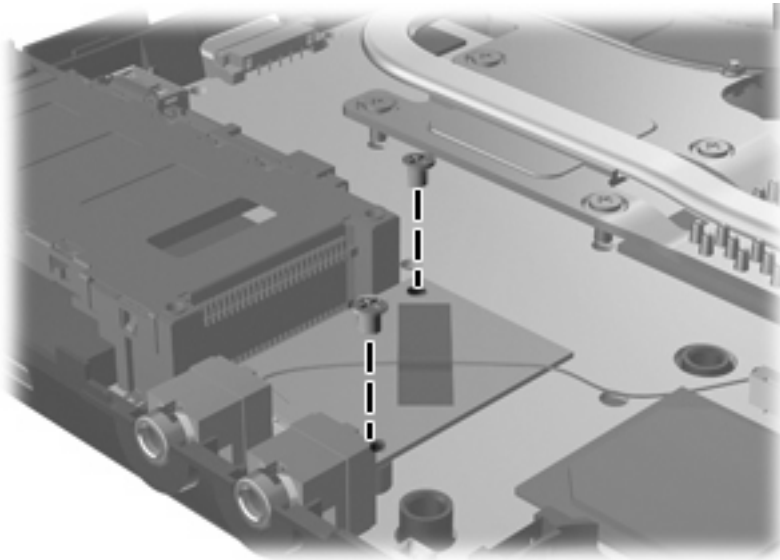

**Where used:** 2 screws that secure the modem module to the computer

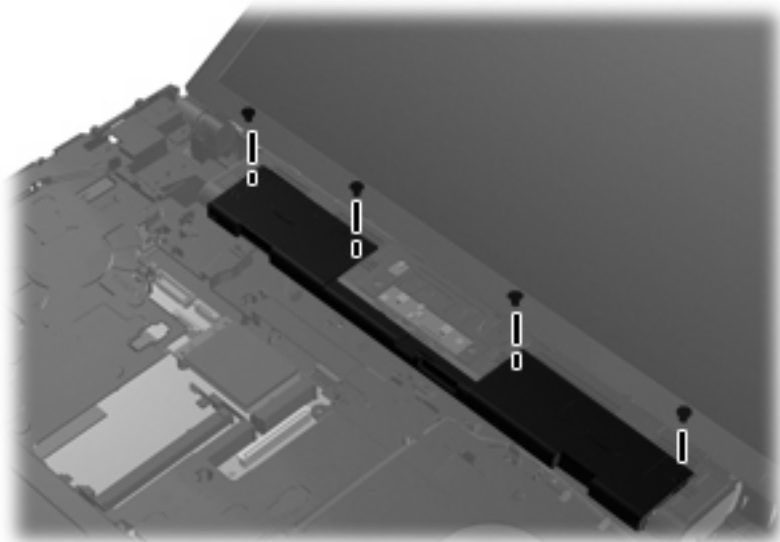

**Where used:** 4 screws that secure the speaker assembly to the computer

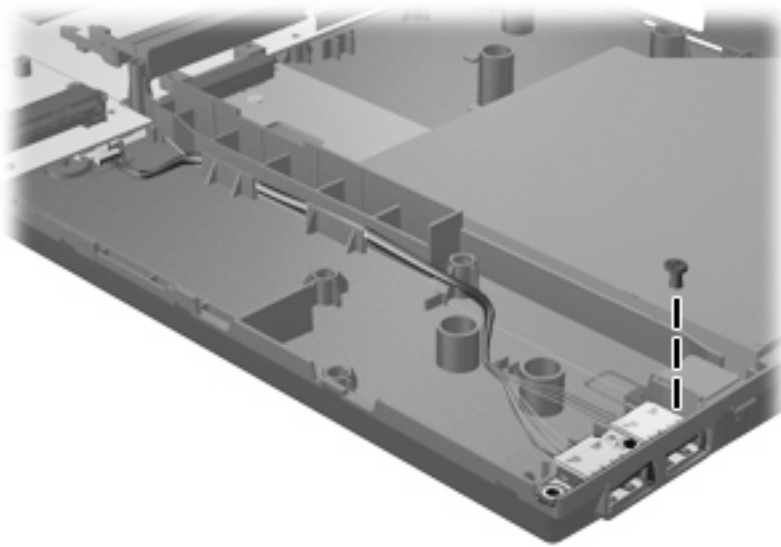

Where used: 1 screw that secures the USB board to the computer

## Phillips PM2.0×2.0 broadhead screw

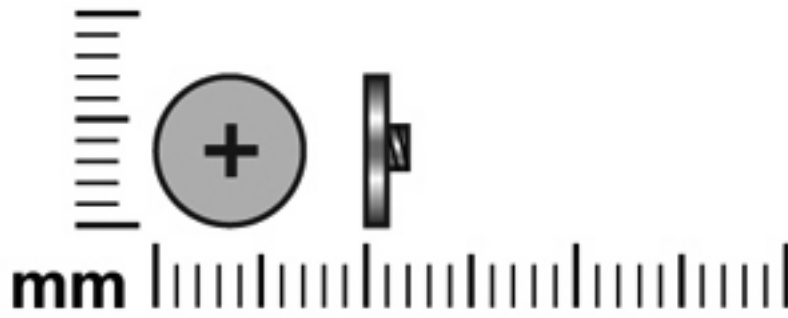

Color	Quantity	Length	Thread	Head diameter
Black	2	2.0 mm	2.0 mm	6.0 mm

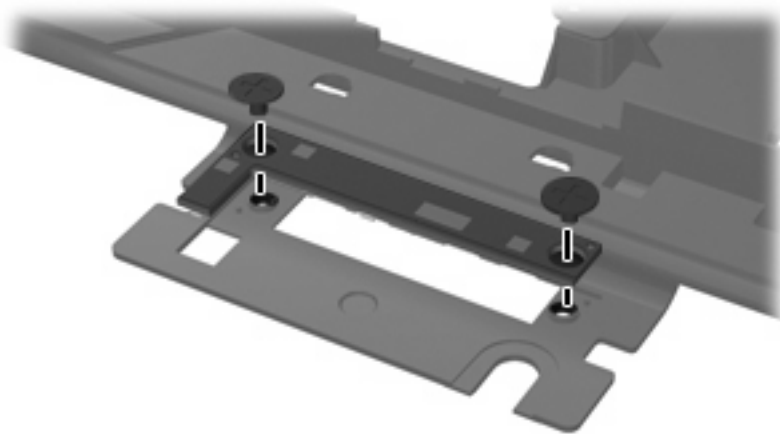

**Where used:** 2 screws that secure the button board to the switch cover

## Phillips PM2.0×3.0 broadhead screw

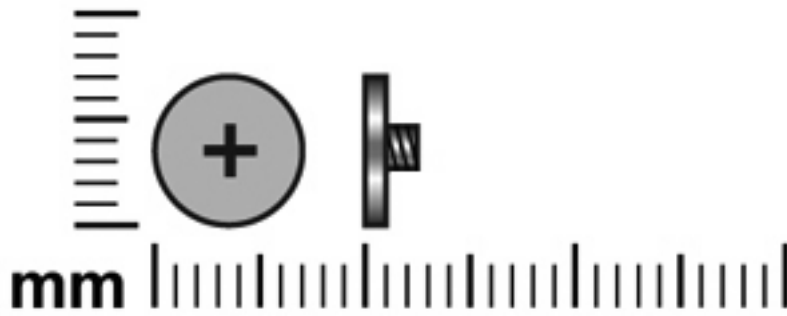

Color	Quantity	Length	Thread	Head diameter
Black	6	3.0 mm	2.0 mm	6.0 mm

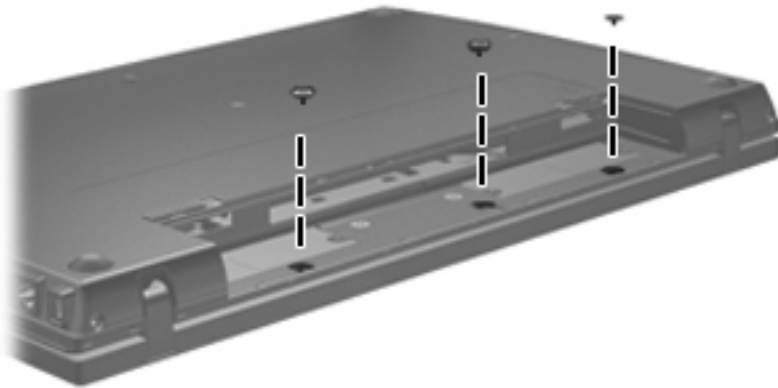

**Where used:** 3 screws that secure the switch cover to the base enclosure

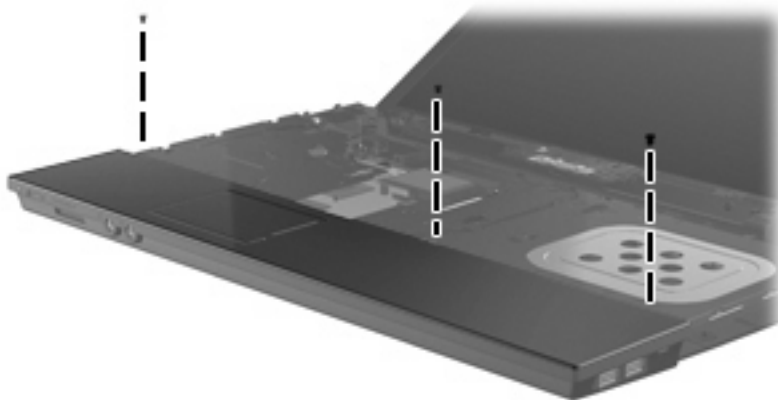

**Where used:** 3 screws that secure the palm rest to the computer

## Phillips PM2.0×4.0 screw

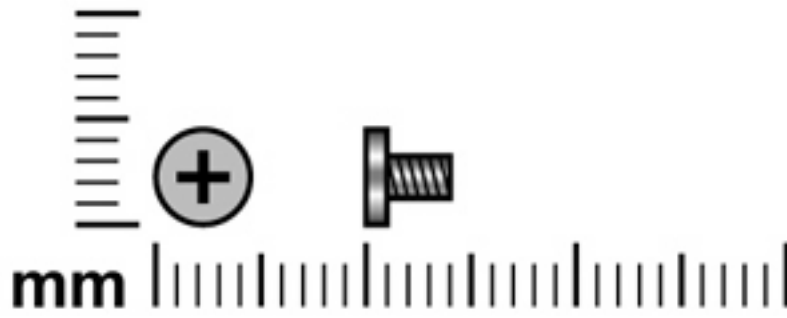

Color	Quantity	Length	Thread	Head diameter
Silver	2	4.0 mm	2.0 mm	4.5 mm

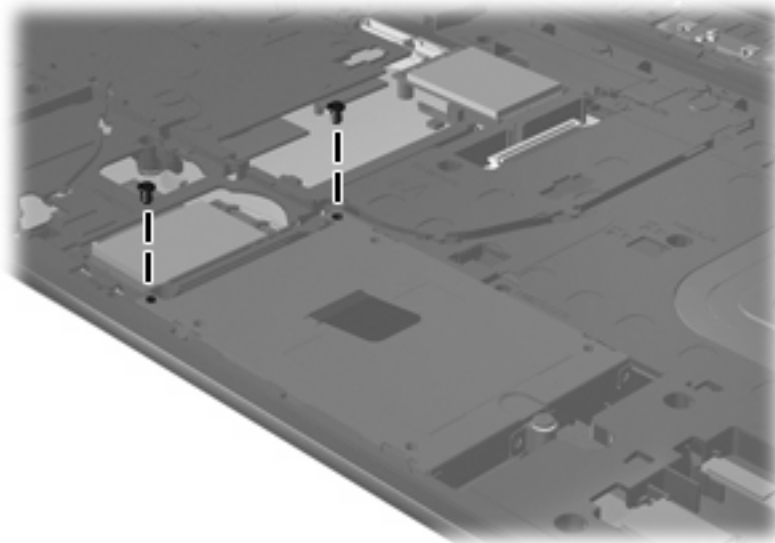

**Where used:** 2 silver screws that secure the hard drive to the top cover

## Phillips PM2.5×9.0 screw

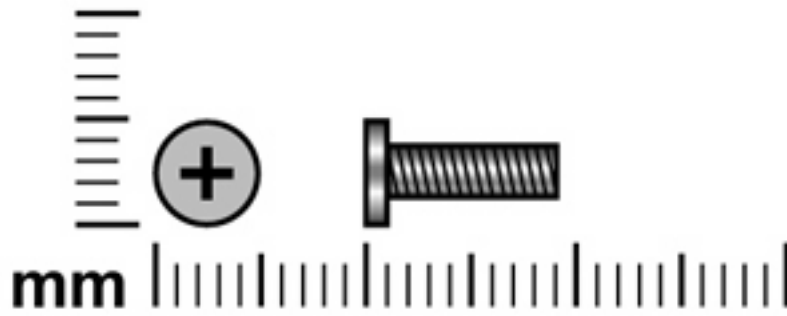

Color	Quantity	Length	Thread	Head diameter
Black	1	9.0 mm	2.5 mm	5.0 mm

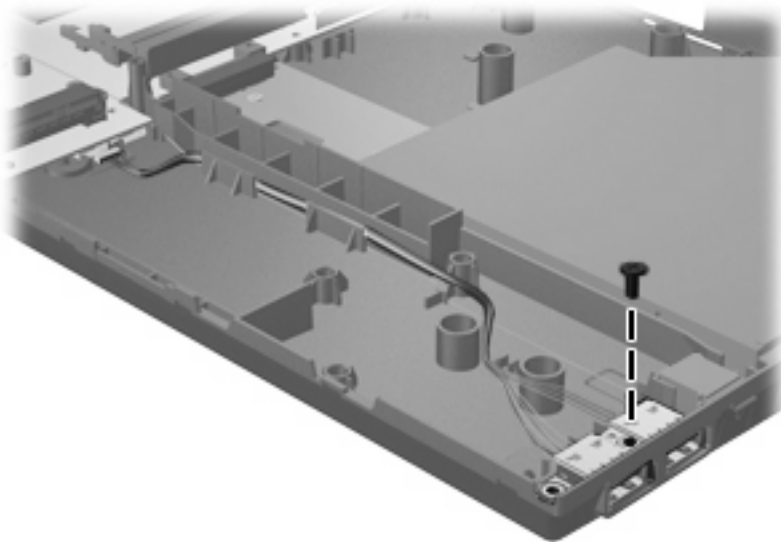

**Where used:** One screw that secures the USB board to the system board

## Phillips PM2.5×10.0 captive screw

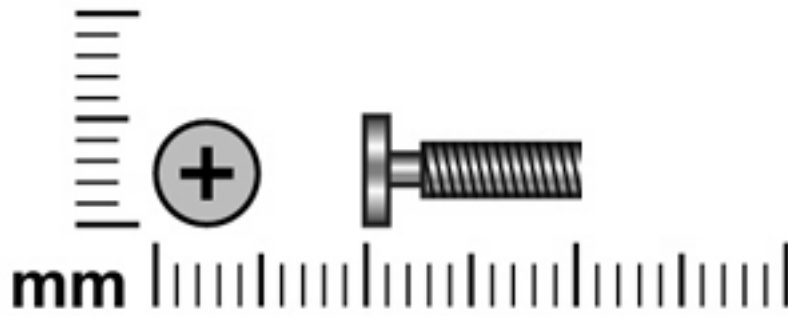

Color	Quantity	Length	Thread	Head diameter
Silver	6	10.0 mm	2.5 mm	5.0 mm

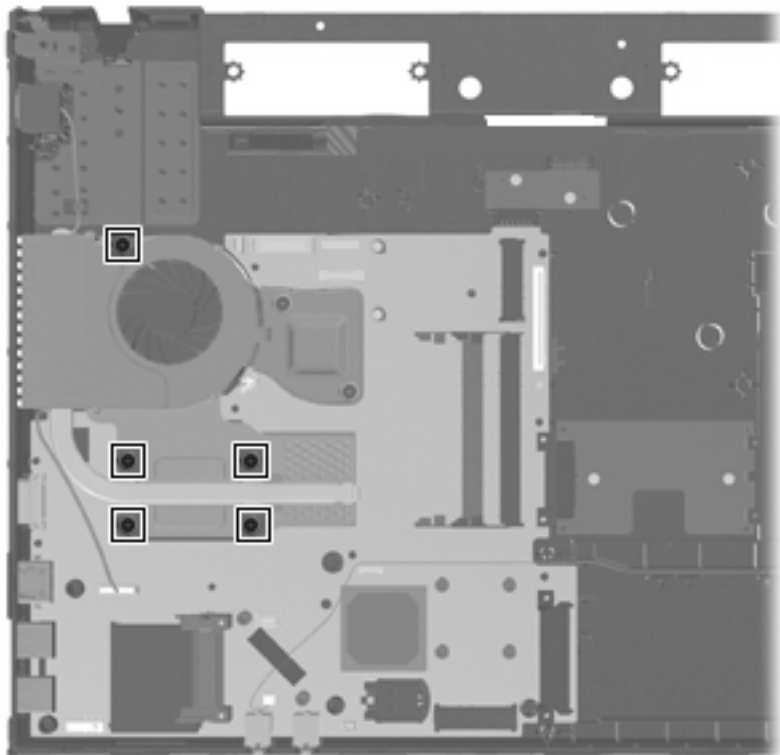

**Where used:** 5 captive screws that secure the heat sink to the system board



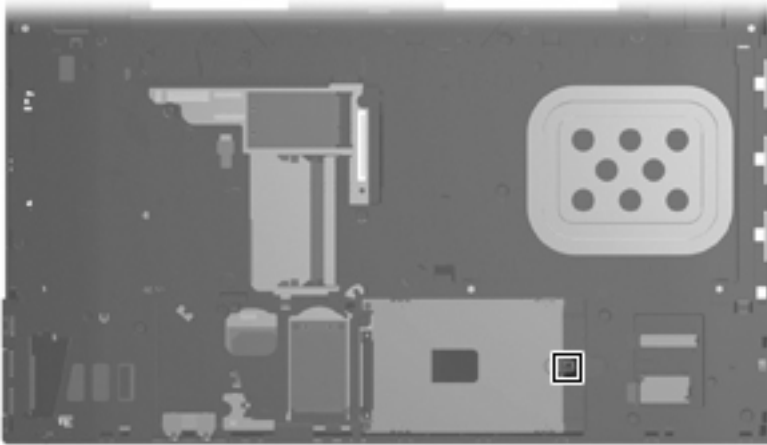

**Where used:** One captive screw that secures the hard drive to the computer (screw is secured to the hard drive bracket)

## Phillips PM2.5×8.0 captive screw

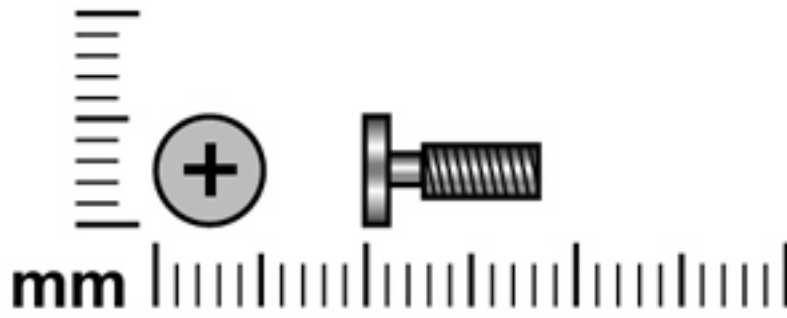

Color	Quantity	Length	Thread	Head diameter
Black	2	8.0 mm	2.5 mm	5.0 mm

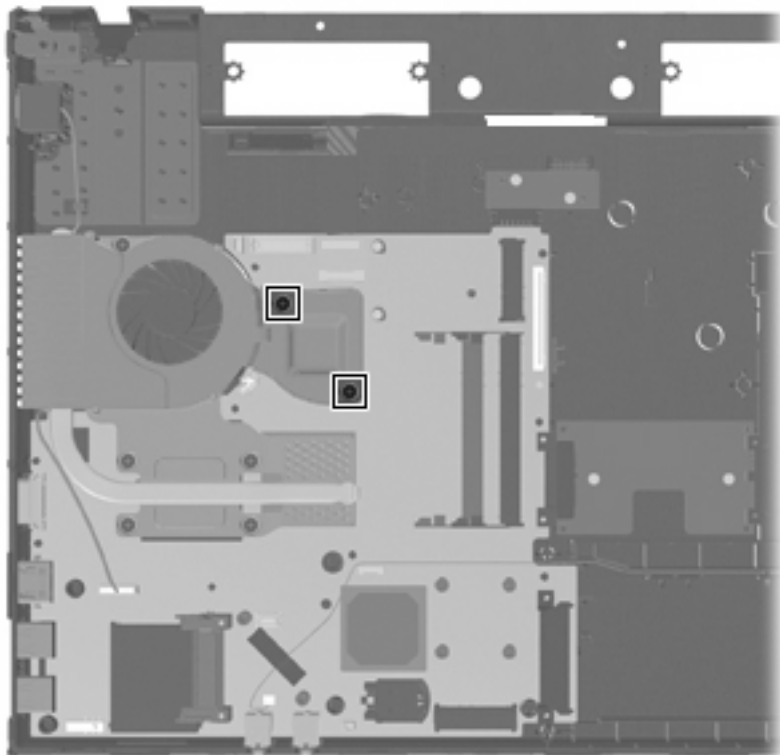

**Where used:** 2 captive screws that secure the heat sink to the computer

## Torx T8M2.5×6.0 screw

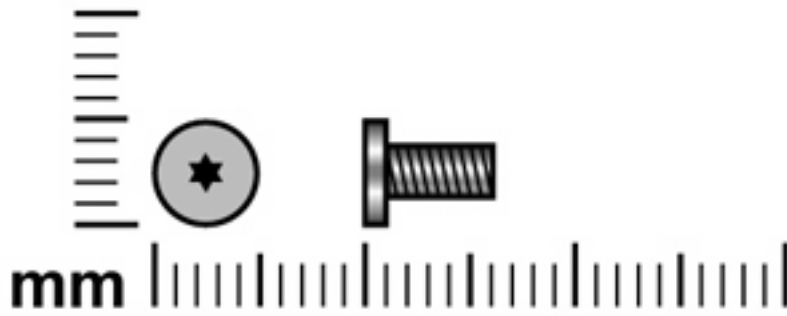

Color	Quantity	Length	Thread	Head diameter
Black	25	6.0 mm	2.5 mm	5.0 mm

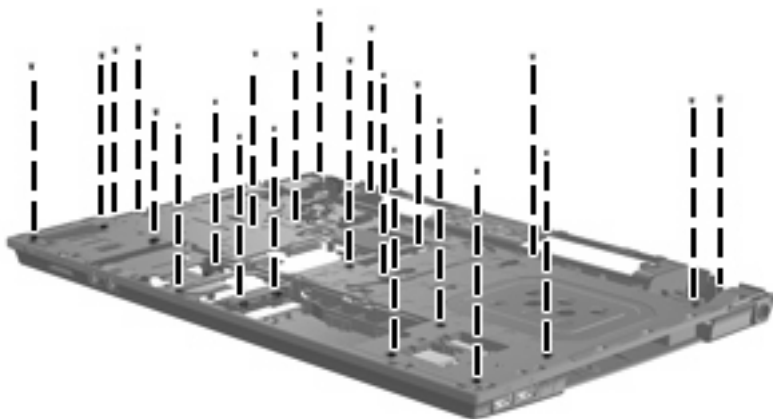
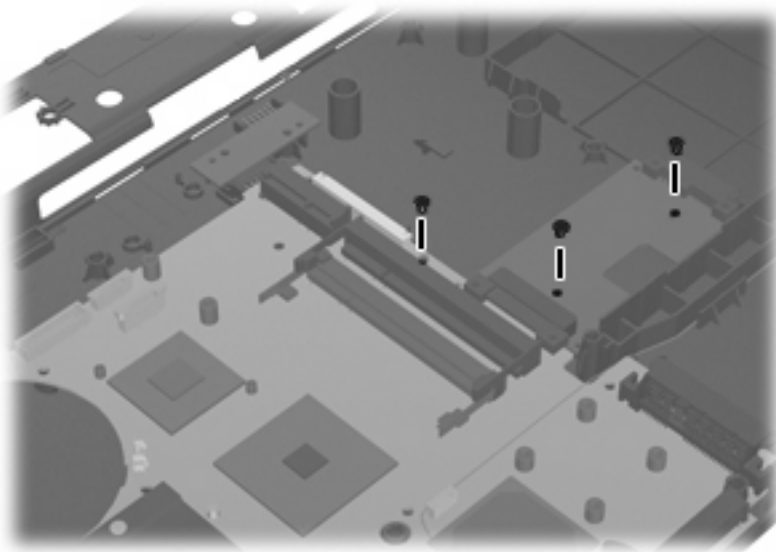

**Where used:** 22 screws that secure the top cover to the base enclosure.

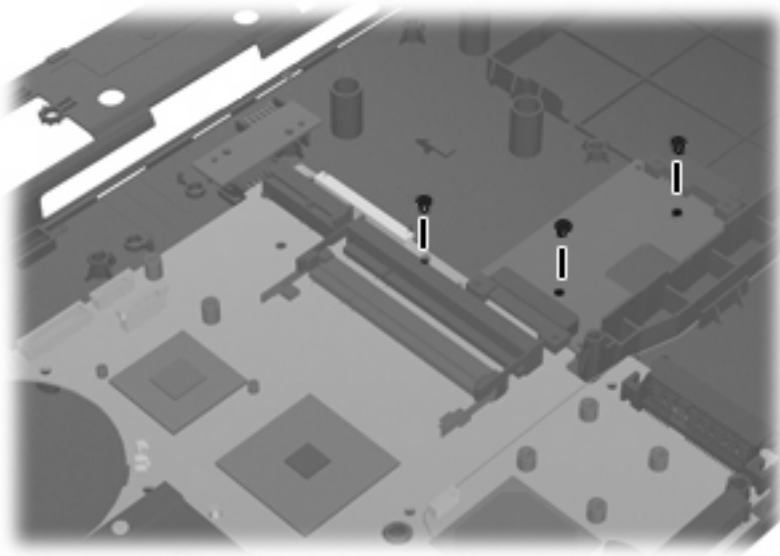

**Where used:** 3 screws that secure the system board to the base enclosure.

---

# 8 Backup and recovery

## Backup and recovery in Windows Vista

### Overview

To protect your information, use the Backup and Restore Center to back up individual files and folders, back up your entire hard drive (select models only), or create system restore points. In case of system failure, you can use the backup files to restore the contents of your computer.

The Backup and Restore Center provides the following options:

- Backing up individual files and folders
- Backing up the entire hard drive (select models only)
- Scheduling automatic backups (select models only)
- Creating system restore points
- Recovering individual files
- Restoring the computer to a previous state
- Recovering information using recovery tools

---

 **NOTE:** For detailed instructions, perform a search for these topics in Help and Support.

**NOTE:** In case of system instability, HP recommends that you print the recovery procedures and save them for later use.

---

### Backing up your information

Recovery after a system failure is as complete as your most current backup. You should create your initial backup immediately after software setup. As you add new software and data files, you should continue to back up your system on a regular basis to maintain a reasonably current backup.

You can back up your information to an optional external hard drive, a network drive, or discs.

Note the following when backing up:

- Store personal files in the Documents folder, and back it up regularly.
- Back up templates that are stored in their associated programs.
- Save customized settings that appear in a window, toolbar, or menu bar by taking a screen shot of your settings. The screen shot can be a time-saver if you have to reset your preferences.

To create a screen shot:

1. Display the screen you want to save.
2. Copy the screen image:

To copy only the active window, press **alt+fn+prt sc**.

To copy the entire screen, press **fn+prt sc**.

3. Open a word-processing document, and then select **Edit > Paste**.

The screen image is added to the document.

4. Save the document.

- When backing up to discs, use any of the following types of discs (purchased separately): CD-R, CD-RW, DVD+R, DVD+R DL, DVD-R, DVD-R DL, or DVD±RW. The discs you use will depend on the type of optical drive installed in your computer.

---

 **NOTE:** DVDs and DVDs with double-layer (DL) support store more information than CDs, so using them for backup reduces the number of recovery discs required.

---

- When backing up to discs, number each disc before inserting it into the optical drive of the computer.

To create a backup using Backup and Restore Center, follow these steps:

---

 **NOTE:** Be sure that the computer is connected to AC power before you start the backup process.

---

**NOTE:** The backup process may take over an hour, depending on file size and the speed of the computer.

---

1. Select **Start > All Programs > Maintenance > Backup and Restore Center**.
2. Follow the on-screen instructions to back up your entire computer (select models only) or your files.

---

 **NOTE:** Windows includes the User Account Control feature to improve the security of your computer. You may be prompted for your permission or password for tasks such as installing software, running utilities, or changing Windows settings. Refer to Help and Support for more information.

---

## Performing a recovery

In case of system failure or instability, the computer provides the following tools to recover your files:

- Windows recovery tools: You can use the Backup and Restore Center to recover information you have previously backed up. You can also use Windows Startup Repair to fix problems that might prevent Windows from starting correctly.
- **f11** recovery tools: You can use the **f11** recovery tools to recover your original hard drive image. The image includes the Windows operating system and software programs installed at the factory.

---

 **NOTE:** If you are unable to boot (start up) your computer, you must purchase a Windows Vista operating system DVD to reboot the computer and repair the operating system. For additional information, refer to the “Using a Windows Vista operating system DVD (purchased separately)” section in this guide.

---

## Using the Windows recovery tools

To recover information you previously backed up, follow these steps:

1. Click **Start > All Programs > Maintenance > Backup and Restore Center**.
2. Follow the on-screen instructions to recover your entire computer (select models only) or your files.

 **NOTE:** Windows includes the User Account Control feature to improve the security of your computer. You may be prompted for your permission or password for tasks such as installing software, running utilities, or changing Windows settings. Refer to Help and Support for more information.

To recover your information using Startup Repair, follow these steps:

△ **CAUTION:** Using Startup Repair completely erases hard drive contents and reformats the hard drive. All files you have created and any software installed on the computer are permanently removed. When reformatting is complete, the recovery process restores the operating system, as well as the drivers, software, and utilities from the backup used for recovery.

1. If possible, back up all personal files.
2. If possible, check for the presence of the Windows partition and the HP Recovery partition. To find the partitions, select **Start > Computer**.

 **NOTE:** If the Windows partition and the HP Recovery partition have been deleted, you must recover your operating system and programs using the Windows Vista operating system DVD and the *Driver Recovery* disc (both purchased separately). For additional information, refer to the “Using a Windows Vista operating system DVD (purchased separately)” section in this guide.

3. Restart the computer, and then press **f8** before the Windows operating system loads.
4. Select **Repair your computer**.
5. Follow the on-screen instructions.

 **NOTE:** For additional information on recovering information using the Windows tools, perform a search for these topics in Help and Support.

## Using f11

△ **CAUTION:** Using **f11** completely erases hard drive contents and reformats the hard drive. All files you have created and any software installed on the computer are permanently removed. The **f11** recovery tool reinstalls the operating system and HP programs and drivers that were installed at the factory. Software not installed at the factory must be reinstalled.

To recover the original hard drive image using **f11**, follow these steps:

1. If possible, back up all personal files.
2. If possible, check for the presence of the HP Recovery partition. To find the partition, select **Start > Computer**.

 **NOTE:** If the HP Recovery partition has been deleted, you must recover your operating system and programs using the Windows Vista operating system DVD and the *Driver Recovery* disc (both purchased separately). For additional information, refer to the “Using a Windows Vista operating system DVD (purchased separately)” section in this guide.

3. Turn on or restart the computer, and then press **esc** while the “Press the ESC key for Startup Menu” message is displayed at the bottom of the screen.

4. Press **f11** while the “Press <F11> for recovery” message is displayed on the screen.
5. Follow the on-screen instructions.

## Using a Windows Vista operating system DVD (purchased separately)

If you are unable to boot (start up) your computer, you must purchase a Windows Vista operating system DVD to reboot the computer and repair the operating system. Make sure that your most recent backup (stored on discs or on an external drive) is easily accessible. To order a Windows Vista operating system DVD, go to <http://www.hp.com/support>, select your country or region, and follow the on-screen instructions. You can also order the DVD by calling technical support. For contact information, refer to the *Worldwide Telephone Numbers* booklet included with the computer.

---

△ **CAUTION:** Using a Windows Vista operating system DVD completely erases hard drive contents and reformats the hard drive. All files you have created and any software installed on the computer are permanently removed. When reformatting is complete, the recovery process helps you restore the operating system, as well as drivers, software, and utilities.

---

To initiate recovery using a Windows Vista operating system DVD, follow these steps:

 **NOTE:** This process takes several minutes.

---

1. If possible, back up all personal files.
2. Restart the computer, and then insert the Windows Vista operating system DVD into the optical drive before the Windows operating system loads.
3. When prompted, press any keyboard key.
4. Follow the on-screen instructions.
5. Click **Next**.
6. Select **Repair your computer**.
7. Follow the on-screen instructions.



# Backup and recovery in Windows XP

## Overview

To protect your information, use the Windows Backup utility (select models only) to back up files and folders or create recovery points. In case of system failure, you can use the backup files to restore your computer.

Windows provides the following options:

- Backing up individual files and folders
- Backing up all files and folders
- Scheduling automatic backups
- Creating recovery points
- Recovering information

---

 **NOTE:** For detailed instructions, perform a search for these topics in Help and Support.

**NOTE:** In case of system instability, HP recommends that you print the recovery procedures and save them for later use.

---

## Backing up your information

Recovery after a system failure is as complete as your most current backup. You should create your initial backup immediately after software setup. As you add new software and data files, you should continue to back up your system on a regular basis to maintain a reasonably current backup.

You can back up individual files or folders to an optional external hard drive or to a network drive.

Note the following when backing up:

- Store personal files in the My Documents folder, and back it up periodically.
- Back up templates stored in their associated programs.
- Save customized settings that appear in a window, toolbar, or menu bar by taking a screen shot of your settings. The screen shot can be a time saver if you have to reset your preferences.

To copy the screen and paste it into a word-processing document:

- a. Display the screen you want to save.
- b. Copy the screen image:  
To copy only the active window, press **alt+fn+prt sc**.  
To copy the entire screen, press **fn+prt sc**.
- c. Open a word-processing document, click **Edit > Paste**.  
The screen image is added to the document.
- d. Save the document.

To create a backup using the Windows Backup utility, follow these steps:

---

 **NOTE:** Be sure that the computer is connected to AC power before you start the backup process.

**NOTE:** The backup process may take over an hour, depending on file size and the speed of the computer.

---

1. Click **Start > All Programs > Accessories > System Tools > Backup**.
2. Follow the on-screen instructions.

## Performing a recovery

In case of system failure or instability, the computer provides the following tools to recover your files:

- Windows recovery tools (select models only): You can use the Windows Backup utility to recover information you have previously backed up.
- *Operating System* and *Driver Recovery* discs (included with your computer): You can use the discs to recover your operating system and programs installed at the factory.

## Recovering your information

To recover information you previously backed up, follow these steps:

1. If possible, back up all personal files.
2. Click **Start > All Programs > Accessories > System Tools > Backup**.

The Backup or Restore Wizard opens.

3. Click **Restore files and settings**, and then click **Next**.
4. Follow the on-screen instructions.

---

 **NOTE:** For additional information on initiating a recovery in Windows, perform a search for this topic in Help and Support.

---

## Recovering the operating system and programs

 **CAUTION:** The recovery process reformats and completely erases the hard drive. All files you have created and any software installed on the computer are permanently removed. The recovery process reinstalls the original operating system, software, and drivers. Software, drivers, and updates not installed by HP must be manually reinstalled.

---

To recover your operating system and programs, follow these steps:

1. If possible, back up all personal files.
2. Insert the *Operating System* disc into the optical drive.
3. Shut down the computer.
4. Turn on the computer.
5. Follow the on-screen instructions to install the operating system.
6. After the operating system is installed, remove the *Operating System* disc and insert the *Driver Recovery* disc.
7. Follow the on-screen instructions to install the drivers and programs.

## 9 Connector pin assignments

### Audio-in (microphone)

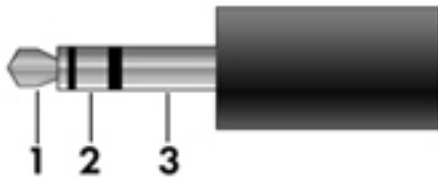

Pin	Signal
1	Audio signal in
2	Audio signal in
3	Ground

### Audio-out (headphone)

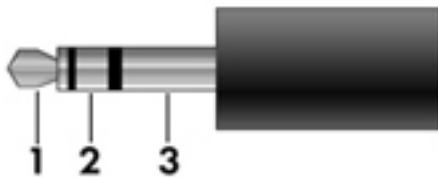

Pin	Signal
1	Audio out, left channel
2	Audio out, right channel
3	Ground

## External monitor

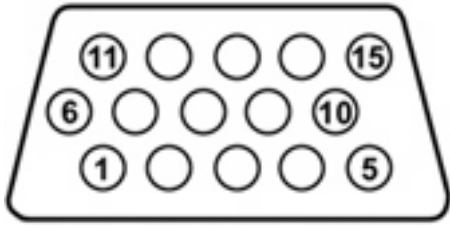

Pin	Signal
1	Red analog
2	Green analog
3	Blue analog
4	Not connected
5	Ground
6	Ground analog
7	Ground analog
8	Ground analog
9	+5 VDC
10	Ground
11	Monitor detect
12	DDC 2B data
13	Horizontal sync
14	Vertical sync
15	DDC 2B clock

# HDMI

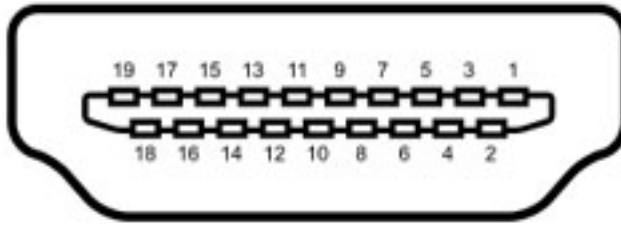

Pin	Signal
1	Transition minimized differential signal (TDMS) data 2+
2	Transition minimized differential signal (TDMS) data 2 shield
3	Transition minimized differential signal (TDMS) data 2-
4	Transition minimized differential signal (TDMS) data 1+
5	Transition minimized differential signal (TDMS) data 1 shield
6	Transition minimized differential signal (TDMS) data 1 shield
7	Transition minimized differential signal (TDMS) data 0+
8	Transition minimized differential signal (TDMS) data 0 shield
9	Transition minimized differential signal (TDMS) data 0-
10	Transition minimized differential signal (TDMS) Clock +
11	Transition minimized differential signal (TDMS) data clock shield
12	Transition minimized differential signal (TDMS) data clock-
13	Consumer electronics control (CEC)
14	No connect
15	Display data channel (DDC) clock
16	Display data channel (DDC) data
17	Ground
18	+5V Power
19	Hot plug detect

## RJ-11 (modem)

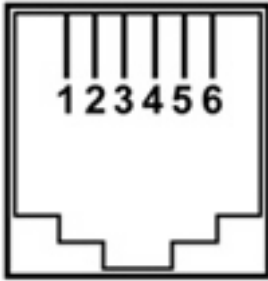

Pin	Signal
1	Unused
2	Tip
3	Ring
4	Unused
5	Unused
6	Unused

## RJ-45 (network)

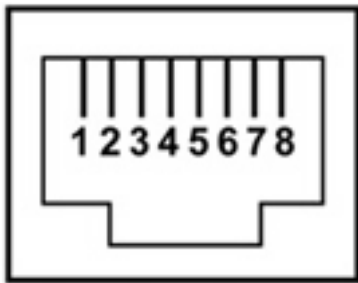

Pin	Signal
1	Transmit +
2	Transmit -
3	Receive +
4	Unused
5	Unused
6	Receive -
7	Unused
8	Unused

## Universal Serial Bus

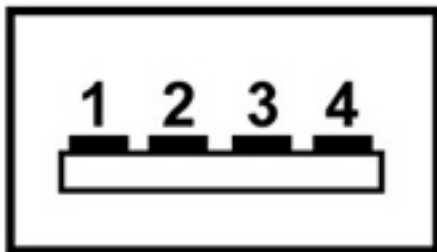

Pin	Signal
1	+5 VDC
2	Data -
3	Data +
4	Ground

---

# 10 Power cord set requirements

The wide range input feature of the computer permits it to operate from any line voltage from 100 to 120 volts AC or from 220 to 240 volts AC.

The 3-conductor power cord set included with the computer meets the requirements for use in the country or region where the equipment is purchased.

Power cord sets for use in other countries and regions must meet the requirements of the country or region where the computer is used.

## Requirements for all countries and regions

The requirements listed below are applicable to all countries and regions:

- The length of the power cord set must be at least 1.5 m (5.0 ft) and no more than 2.0 m (6.5 ft).
- All power cord sets must be approved by an acceptable accredited agency responsible for evaluation in the country or region where the power cord set will be used.
- The power cord sets must have a minimum current capacity of 10 amps and a nominal voltage rating of 125 or 250 V AC, as required by the power system of each country or region.
- The appliance coupler must meet the mechanical configuration of an EN 60 320/IEC 320 Standard Sheet C13 connector for mating with the appliance inlet on the back of the computer.



## Requirements for specific countries and regions

Country/region	Accredited agency	Applicable note number
Australia	EANSW	1
Austria	OVE	1
Belgium	CEBC	1
Canada	CSA	2
Denmark	DEMKO	1
Finland	FIMKO	1
France	UTE	1
Germany	VDE	1
Italy	IMQ	1
Japan	METI	3
The Netherlands	KEMA	1
Norway	NEMKO	1
The People's Republic of China	CCC	5
South Korea	EK	4
Sweden	SEMKO	1
Switzerland	SEV	1
Taiwan	BSMI	4
The United Kingdom	BSI	1
The United States	UL	2

1. The flexible cord must be Type HO5VV-F, 3-conductor, 1.0-mm<sup>2</sup> conductor size. Power cord set fittings (appliance coupler and wall plug) must bear the certification mark of the agency responsible for evaluation in the country or region where it will be used.
2. The flexible cord must be Type SPT-3 or equivalent, No. 18 AWG, 3-conductor. The wall plug must be a two-pole grounding type with a NEMA 5-15P (15 A, 125 V) or NEMA 6-15P (15 A, 250 V) configuration.
3. The appliance coupler, flexible cord, and wall plug must bear a "T" mark and registration number in accordance with the Japanese Dentori Law. The flexible cord must be Type VCT or VCTF, 3-conductor, 1.00-mm<sup>2</sup> conductor size. The wall plug must be a two-pole grounding type with a Japanese Industrial Standard C8303 (7 A, 125 V) configuration.
4. The flexible cord must be Type RVV, 3-conductor, 0.75-mm<sup>2</sup> conductor size. Power cord set fittings (appliance coupler and wall plug) must bear the certification mark of the agency responsible for evaluation in the country or region where it will be used.
5. The flexible cord must be Type VCTF, 3-conductor, 0.75-mm<sup>2</sup> conductor size. Power cord set fittings (appliance coupler and wall plug) must bear the certification mark of the agency responsible for evaluation in the country or region where it will be used.

---

# 11 Recycling

## Battery

When a battery has reached the end of its useful life, do not dispose of the battery in general household waste. Follow the local laws and regulations in your area for computer battery disposal.

## Display

- ⚠ **WARNING!** The backlight contains mercury. Exercise caution when removing and handling the backlight to avoid damaging this component and causing exposure to the mercury.
- ⚠ **CAUTION:** The procedures in this chapter can result in damage to display components. The only components intended for recycling purposes are the liquid crystal display (LCD) panel and the backlight. When you remove these components, handle them carefully.
- 📄 **NOTE: Materials Disposal.** This HP product contains mercury in the backlight in the display assembly that might require special handling at end-of-life. Disposal of mercury may be regulated because of environmental considerations. For disposal or recycling information, contact your local authorities, or see the Electronic Industries Alliance (EIA) Web site at <http://www.eiae.org>.

This section provides disassembly instructions for the display assembly. The display assembly must be disassembled to gain access to the backlight **(1)** and the liquid crystal display (LCD) panel **(2)**.



- 📄 **NOTE:** The procedures provided in this chapter are general disassembly instructions. Specific details, such as screw sizes, quantities, and locations, and component shapes and sizes, can vary from one computer model to another.

Perform the following steps to disassemble the display assembly:

1. Remove all screw covers (1) and screws (2) that secure the display bezel to the display assembly.

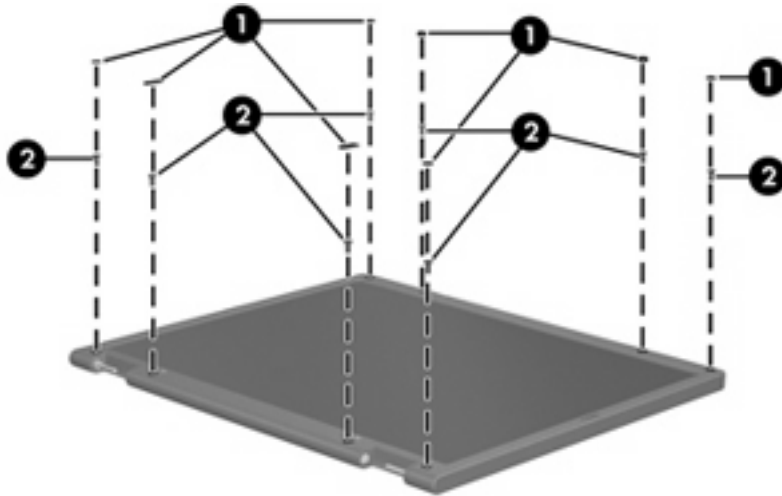

2. Lift up and out on the left and right inside edges (1) and the top and bottom inside edges (2) of the display bezel until the bezel disengages from the display assembly.
3. Remove the display bezel (3).

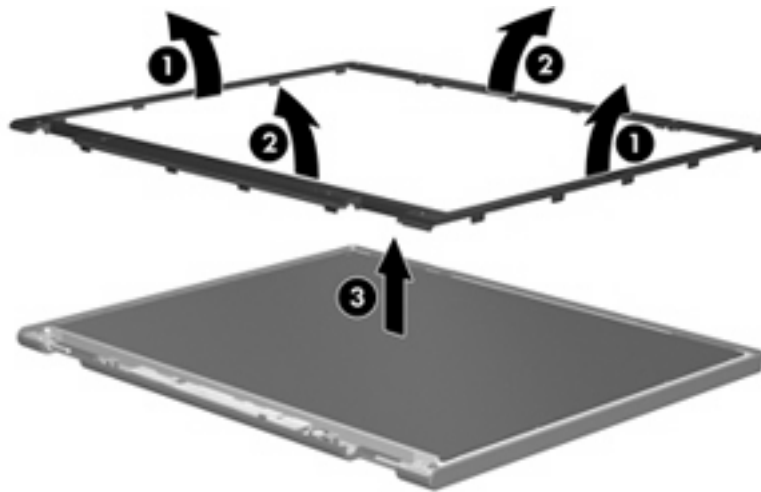

4. Remove all screws (1) that secure the display panel assembly to the display enclosure.

5. Remove the display panel assembly (2) from the display enclosure.

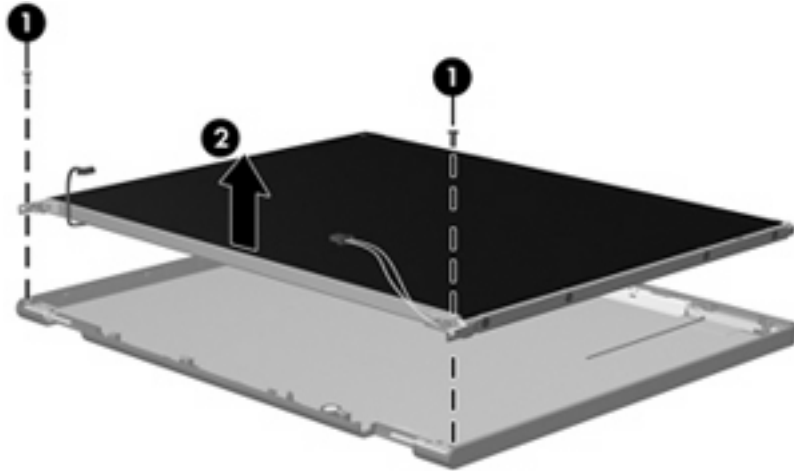

6. Turn the display panel assembly upside down.
7. Remove all screws that secure the display panel frame to the display panel.

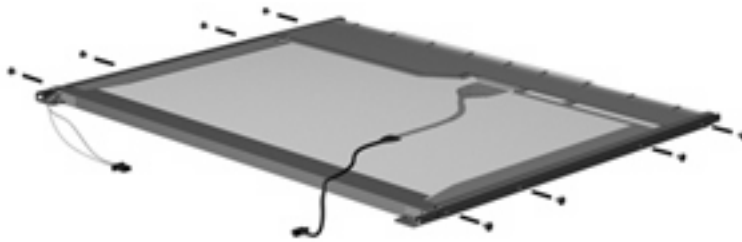

8. Use a sharp-edged tool to cut the tape (1) that secures the sides of the display panel to the display panel frame.
9. Remove the display panel frame (2) from the display panel.

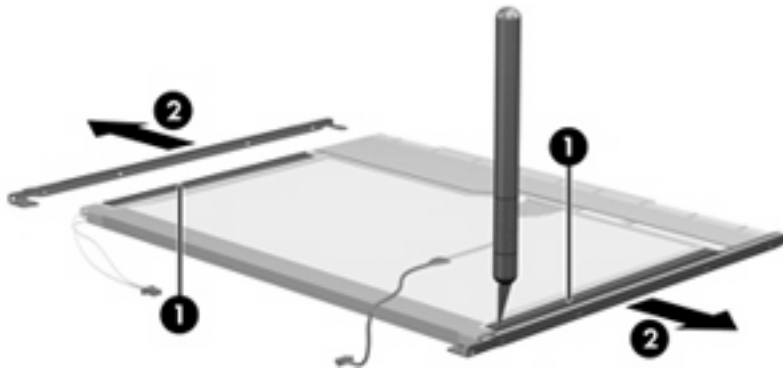

10. Remove the screws (1) that secure the backlight cover to the display panel.

11. Lift the top edge of the backlight cover (2) and swing it outward.

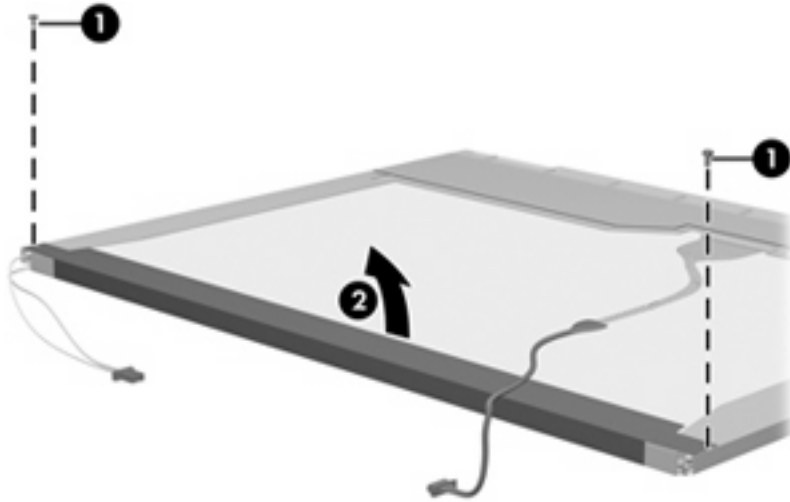

12. Remove the backlight cover.
13. Turn the display panel right-side up.
14. Remove the backlight cables (1) from the clip (2) in the display panel.

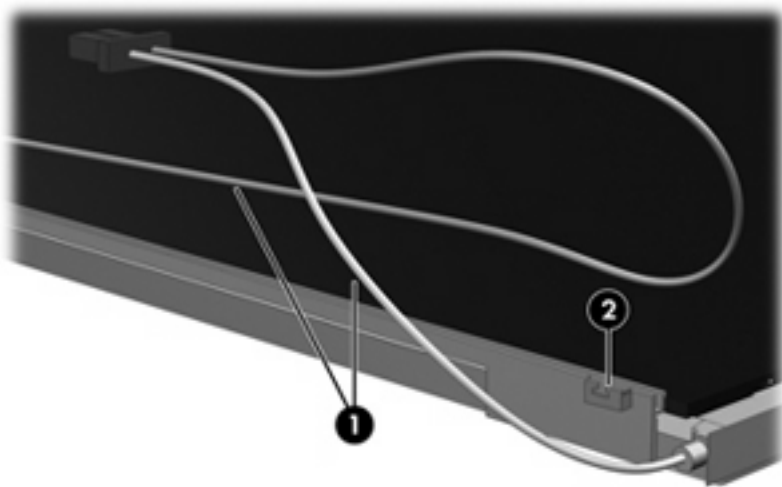

15. Turn the display panel upside down.

**⚠ WARNING!** The backlight contains mercury. Exercise caution when removing and handling the backlight to avoid damaging this component and causing exposure to the mercury.

16. Remove the backlight frame from the display panel.

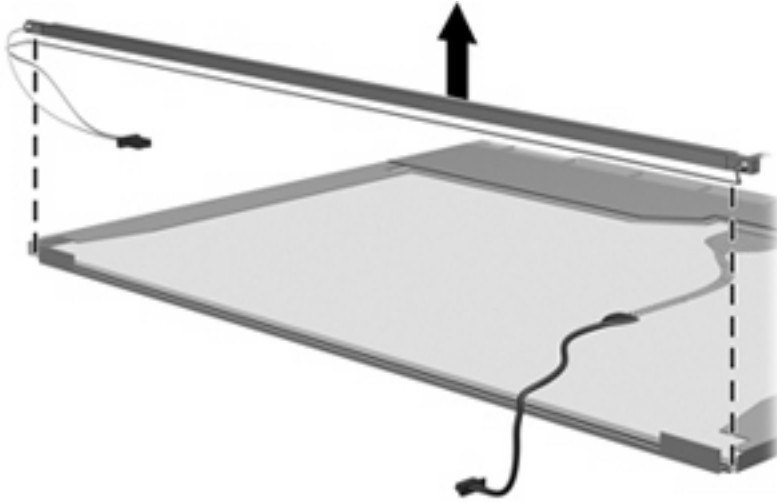

17. Remove the backlight from the backlight frame.

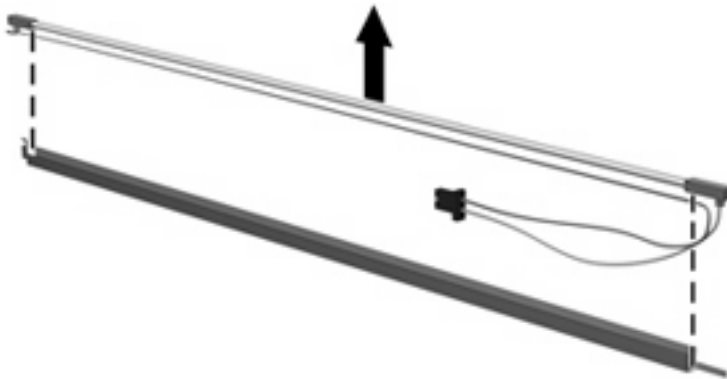

18. Disconnect the display panel cable (1) from the LCD panel.
19. Remove the screws (2) that secure the LCD panel to the display rear panel.
20. Release the LCD panel (3) from the display rear panel.
21. Release the tape (4) that secures the LCD panel to the display rear panel.

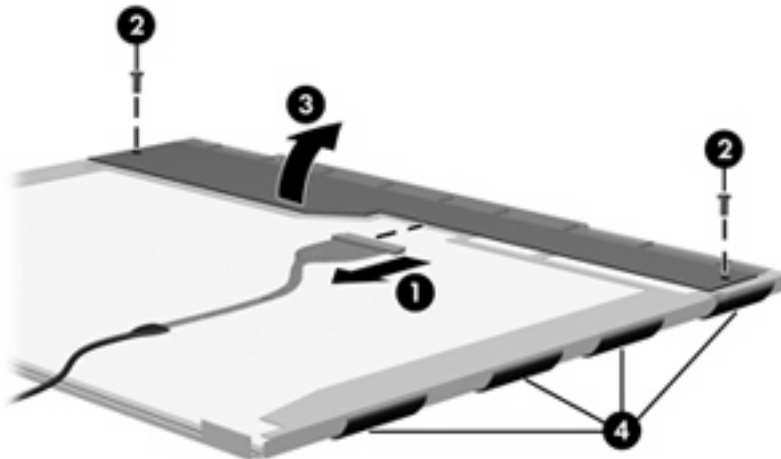

22. Remove the LCD panel.

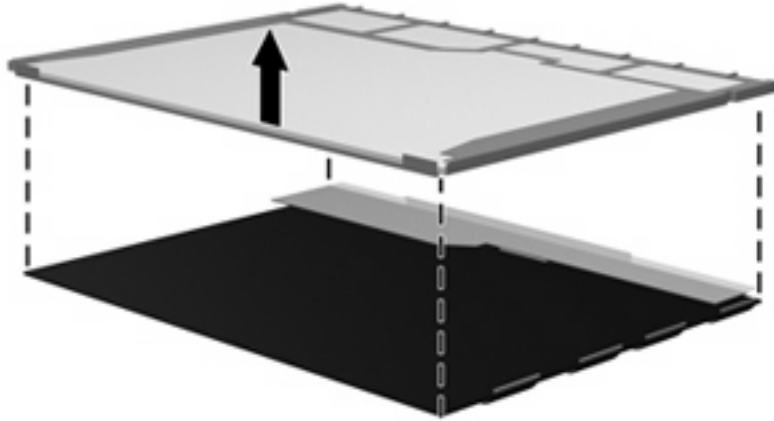

23. Recycle the LCD panel and backlight.

---

# Index

- A**
  - AC adapter, spare part
    - number 27, 28
  - antenna, disconnecting 57
  - audio, product description 3
  - audio-in (microphone) jack
    - location 11
    - pin assignments 129
  - audio-out (headphone) jack
    - location 11
    - pin assignments 129
- B**
  - backing up, Windows Vista 123
  - backing up, Windows XP 127
  - Backup and Restore Center 123, 124
  - base enclosure, spare part
    - number 21, 30
  - battery
    - location 14
    - removal 41
    - spare part number 22, 30, 41
  - battery bay 14
  - battery board connector, spare part
    - number 30
  - battery latches 14
  - battery light 12
  - BIOS administrator password 85
  - Blu-ray ROM with LightScribe DVD ±RW SuperMulti DL Drive
    - precautions 35
    - removal 47
    - spare part number 21, 26, 30, 47
    - specifications 98
  - Bluetooth module
    - removal iii
    - spare part number 21, 28, 30, iii
  - boot options 87
  - boot order 87
  - bottom components 14
  - built-in device options 88
  - button components 8
  - buttons
    - Info Center 8
    - power 9
    - QuickLook 8
    - TouchPad 7
- C**
  - cables, service considerations 35
  - caps lock light 8
  - chipset, product description 1
  - components
    - bottom 14
    - buttons 8
    - display 6
    - front 11
    - keys 9
    - left-side 13
    - lights 8
    - pointing devices 7
    - right-side 12
    - speakers 8
    - top 6
    - TouchPad 7
  - computer feet
    - locations 40
    - spare part number 40
  - Computer Setup
    - accessing in Linux 89
    - accessing in Windows 83
    - Diagnostics menu in Linux 91
  - Diagnostics menu in
    - Windows 86
  - File menu 90
  - File menu in Windows 85
  - navigating and selecting in
    - Linux 89
    - Windows 83
  - restoring factory settings in
    - Linux 90
    - Windows 84
  - Security menu in Linux 90
  - Security menu in Windows 85
  - System Configuration menu in
    - Linux 91
    - Windows 86
    - using in Linux 89
    - using in Windows 83
  - computer specifications 94
  - connectors
    - power 12
    - service considerations 35
- D**
  - device configurations 87
  - Diagnostics menu
    - Linux 91
    - Windows 86
  - discs
    - Driver Recovery 128
    - Operating System 128
  - Disk Sanitizer 86
  - diskette drive
    - precautions 35
    - product description 3
  - display
    - components 6
    - illustrated 6



- display assembly
  - removal iii
  - spare part number 31, iii
- display bezel
  - removal 61
  - spare part number 17, 30, 61
- display cable kit, spare part number 31, 63
- display component recycling 136
- display components 6
- display enclosure, spare part number 16, 24, 30
- display hardware kit, spare part number 27
- display hinge
  - removal 62
  - spare part number 17, 31, 62
- display panel, removal 62
- display specifications 95
- drive light 11
- DriveLock password 85
- DriveLock, automatic 85
- Driver Recovery disc 128
- drives
  - boot order 87
  - preventing damage 35
- Dual-Core CPU 87
- DVD-ROM Drive
  - spare part number 21, 26, 47
  - specifications 99
- DVD±RW and CD-RW SuperMulti Double-Layer Combo Drive with LightScribe
  - spare part number 21, 26, 30, 47
  - specifications 97

**E**

- electrostatic discharge 36
- esc key 9
- Ethernet, product description 3
- Execution Disable 87
- ExpressCard assembly, spare part number 18, 32
- ExpressCard slot 13
- ExpressCard slot bezel, illustrated 24

- external monitor port
  - location 13
  - pin assignments 130

**F**

- f11 recovery 125
- fan
  - removal 74
  - spare part number 18, 74
- feet
  - locations 40
  - spare part number 40
- File menu
  - Linux 90
  - Windows 85
- fn key 9
- front components 11
- function keys 10

**G**

- graphics, product description 1
- grounding equipment and methods 38

**H**

- hard disk test 86
- hard drive
  - precautions 35
  - product description 2
  - removal iii
  - spare part numbers 21, 26, 30, iii
  - specifications 96
- hard drive bracket, removal 53
- hard drive recovery 125
- HDMI port
  - location 13
  - pin assignments 131
- headphone (audio-out) jack
  - location 11
  - pin assignments 129
- heat sink
  - removal 74
  - spare part number 18, 30, 74
- hinge
  - removal 62
  - spare part number 17, 62
- HP QuickLook 2 87

**I**

- I/O address specifications 101
- Info Center 8
- internal display switch 6
- interrupt specifications 100

**J**

- jacks
  - audio-in 11
  - audio-out 11
  - headphone 11
  - microphone 11
  - modem (RJ-11) 12
  - network (RJ-45) 13

**K**

- key components 9
- keyboard
  - product description 4
  - removal 42
  - spare part numbers 17, 31, 42
- keypad keys 10
- keys
  - esc 9
  - fn 9
  - function 10
  - keypad 10
  - Windows applications 9
  - Windows logo 9

**L**

- language, changing in Computer Setup 86
- left-side components 13
- legacy support, USB 83, 87
- light components 8
- lights
  - battery 12
  - caps lock 8
  - drive 11
  - optical drive 12
  - power 9
  - wireless 11
- Logo Kit, spare part number 27

**M**

- mass storage devices, spare part numbers iii
- Media Card Reader 11
- memory map specifications 103

- memory module
  - product description 2
  - removal iii
  - spare part number 31
  - spare part numbers iii
- microphone (audio-in) jack
  - location 11
  - pin assignments 129
- microphone, internal 6
- model name 1
- modem (RJ-11) jack
  - location 12
  - pin assignments 132
- modem module
  - product description 3
  - removal 68
  - spare part number 18, 29, 68
- monitor port
  - location 13
  - pin assignments 130

## N

- network (RJ-45) jack
  - location 13

## O

- Operating System disc 128
- operating system, product
  - description 4
- optical disk drive connector board,
  - spare part number 30
- optical drive
  - bezel 24
  - location 12
  - precautions 35
  - product description 3
  - removal 47
  - spare part numbers 21, 26, 47
  - specifications 97, 98, 99
- optical drive light 12

## P

- packing guidelines 37
- palm rest
  - removal 50
  - spare part number 31, 50
- panels, product description 1
- passwords 85

- pin assignments
  - audio-in (microphone)
    - jack 129
  - audio-out (headphone)
    - jack 129
  - external monitor port 130
  - HDMI 131
  - headphone (audio-out)
    - jack 129
  - microphone (audio-in)
    - jack 129
  - modem (RJ-11) jack 132
  - monitor port 130
  - network (RJ-45) jack 133
  - RJ-11 132
  - Universal Serial Bus (USB)
    - port 133
- plastic parts 34
- Plastics Kit
  - contents 24
  - spare part number 24, 31
- pointing device
  - description 4
  - illustrated 7
- pointing device components
  - TouchPad 7
  - TouchPad buttons 7
  - TouchPad scroll zone 7
- port options 88
- ports
  - external monitor 13
  - HDMI 13
  - monitor 13
  - product description 4
  - Universal Serial Bus (USB) 12, 13
- power button 9
- power button board
  - removal 67
  - spare part number 67
- power connector 12
- power connector cable,
  - illustrated 25
- power cord
  - set requirements 134
  - spare part number 28
  - spare part numbers 27
- power light 9
- power requirements, product
  - description 4

- processor
  - product description 1
  - removal iii
  - spare part numbers 18, 29, iii, 78
- product description
  - audio 3
  - chipset 1
  - diskette drive 3
  - Ethernet 3
  - external media cards 4
  - graphics 1
  - hard drives 2
  - keyboard 4
  - memory module 2
  - modem module 3
  - operating system 4
  - optical drives 3
  - panels 1
  - pointing device 4
  - ports 4
  - power requirements 4
  - processors 1
  - product description 4
  - product name 1
  - security 4
  - serviceability 5
  - wireless 3
- product name 1

## Q

- QuickLook 8

## R

- recovery partition 125
- removal/replacement
  - preliminaries 34
  - procedures 39
- restore security defaults 88
- restore the factory settings 85
- restoring the hard drive 125
- right-side components 12
- RJ-11 (modem) jack
  - location 12
  - pin assignments 132
- RJ-11 (modem) jack cable,
  - illustrated 25
- RJ-45 (network) jack
  - location 13
  - pin assignments 133

- removal 76
- spare part number 76
- RJ-45 (network) jack cable, illustrated 25
- RTC battery
  - removal 72
  - spare part number 21, 28, 72
- rubber kit, spare part number 31, 40
- run-in test 86

**S**

- SATA (Serial Advanced Technology Attachment) devices
  - AHCI (Advanced Host Controller Interface) 87
  - IDE (Integrated Drive Electronics) 87
- Screw Kit
  - contents 104
  - spare part number 27, 31
- screw listing 104
- security cable slot 13
- Security menu
  - Automatic DriveLock 85
  - change password 85
  - Disk Sanitizer 86
  - DriveLock 85
  - HP SpareKey 85
  - HP SpareKey enrollment 85
  - Linux 90
  - password policy 85
  - set up BIOS Administrator password 85
  - System IDs 86
  - user management 85
  - Windows 85
- security, product description 4
- service considerations 34
- service tag 15, 39
- serviceability, product description 5
- set security level 88
- setup utility
  - Diagnostics menu in Linux 91
  - Diagnostics menu in Windows 86
  - File menu 90
  - File menu in Windows 85

- navigating and selecting in Linux 89
- navigating and selecting in Windows 83
- restoring factory settings in Linux 90
- restoring factory settings in Windows 84
- Security menu in Linux 90
- Security menu in Windows 85
- System Configuration menu in Linux 91
- System Configuration menu in Windows 86
- speaker kit
  - spare part number 31
- speakers
  - location 8
  - removal 49
  - spare part number 18, 49
- specifications
  - Blu-ray ROM with LightScribe DVD±RW SuperMulti DL Drive 98
  - computer 94
  - display 95
  - DVD-ROM Drive 99
  - DVD±RW and CD-RW SuperMulti Double-Layer Combo Drive with LightScribe 97
  - hard drive 96
  - I/O addresses 101
  - interrupts 100
  - memory map 103
  - optical drive 97, 98, 99
  - system DMA 99
- start-up test 86
- static-shielding materials 38
- switch cover
  - removal 42
  - spare part number 17, 30, 42
- switches
  - internal display 6
  - wireless 11
- system board
  - removal iii
  - spare part number 18, 32, iii

- System Configuration menu
  - Linux 91
  - Windows 86
- system date and time 85
- System Diagnostics menu 86
- system DMA 99
- system fan 87
- system IDs 86
- system information 85
- system memory map 103

**T**

- thermal material, replacement 76
- tools required 34
- top components 6
- top cover
  - removal iii
  - spare part number 18, 31, iii
- TouchPad 7
- TouchPad buttons 7
- TouchPad cable, illustrated 25
- TouchPad scroll zone 7
- transporting guidelines 37

**U**

- Unified Extensible Firmware Interface (UEFI) mode 87
- USB cable, illustrated 25
- USB connector and cable, spare part number 21
- USB connector module, removal 70
- USB legacy support 83, 87
- USB port
  - location 13
  - pin assignments 133
- USB port, location 12

**V**

- vents 13
- Virtualization Technology 87

**W**

- webcam module, spare part number 31
- Windows applications key 9
- Windows Backup utility 127, 128
- Windows logo key 9
- Windows recovery 124, 128
- Windows Vista operating system DVD 126

- wireless light 11
- wireless switch 11
- wireless, product description 3
- WLAN antennas
  - disconnecting 57
  - location 6
- WLAN module
  - removal iii
  - spare part numbers 19, iii
- workstation guidelines 37

